

MODEL GS

Single Wall Grease Duct Installation Guidelines

Tested to UL1978/ULCS662

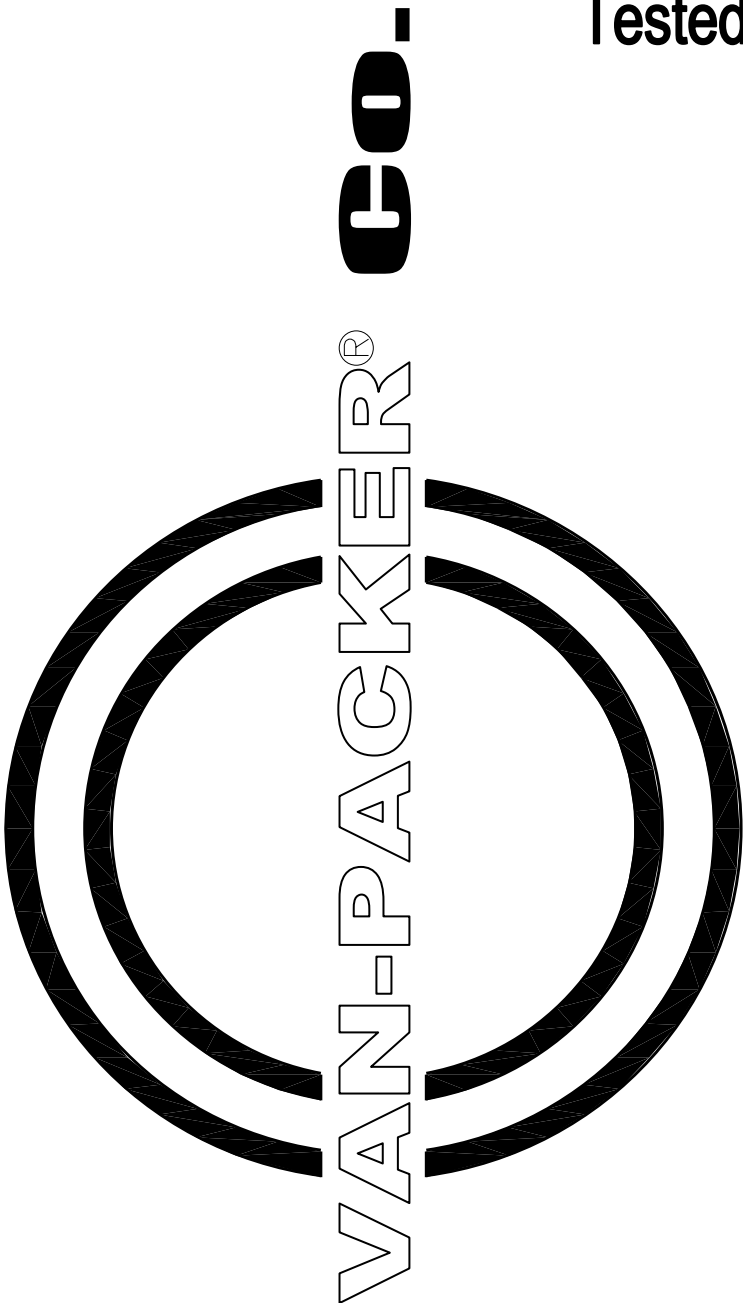

TABLE OF CONTENTS

LISTING & CODE COMPLIANCE	3
TESTING, CLASSIFICATION, & APPLICATIONS.	3
GENERAL INFORMATION	3-5
CLEARANCES & ADDITIONAL ENCLOSURES	3
CODES & AUTHORITIES.	3
INSTALLATION CONSIDERATIONS	3
MIXING SYSTEMS & PARTS.	4
DUCT SLOPE.	4
CLEANOUTS, DRAINS, & GREASE TRAPS	4
WASH DOWN & FIRE SUPPRESSION.	5
RECEIVING INSPECTION	5
TYPICAL COMPONENT LOCATIONS	5
FREIGHT DAMAGE.	5
PART IDENTIFICATION & MATERIAL CODES	5
JOINT ASSEMBLY	6
SEALANT USAGE.	7
INSTALLED WEIGHT CHART.	7
SUPPORT LOAD LIMITATIONS.	7
DUCT SECTIONS & FITTINGS	8-10
ADAPTERS	8
FITTINGS & STRAIGHT SECTIONS	8
ACCESS PANEL & GREASE DRAINS	9
TERMINATIONS	9
ADJUSTABLE AND VARIABLE LENGTH SECTIONS	10
SUPPORTS & GUIDES.	11-13
STRUCTURAL SUPPORTS.	11-12
HORIZONTAL SUPPORT HANGER	12
LATERAL BRACES & GUIDES.	13
PENETRATIONS.	14
FLOORS / CEILINGS & WALLS - FIRE RATING NOT REQUIRED	14
ROOF PENETRATIONS	14
SYSTEM INSTALLATION EXAMPLE.	15

WARNING

Major causes of grease duct fires are failure to maintain required clearance to combustibles and failure to clean and remove grease build-up from the duct system. It is important to read and understand these instructions fully before installing this grease duct system. Failure to comply with these instructions will result in a hazardous installation and will void the warranty.

STANDARD WARRANTY

When this system, provided by the Van-Packer Company, is installed per these instructions, we warrant the parts be free from defects in material and workmanship for a period of 12 months from the date of shipment. For warranty questions please contact the technical service department for further details and stipulations.

LISTING & CODE COMPLIANCE

Van-Packer's Model GS grease duct is listed by UL as "18 inch clearance to combustibles grease duct assembly" and as "Grease Ducts for Restaurant Cooking Appliances" when installed in accordance with these instructions and the National Fire Protection Association's standard NFPA 96 "Standard for Ventilation Control and Fire Protection of Commercial Cooking Operations," International Mechanical Code, Uniform Mechanical Code, or other local codes.

TESTING, CLASSIFICATION, & APPLICATIONS

Model GS has been tested in accordance with the procedures and methods set forth by UL 1978/ULC S662 (*Standard for Grease Ducts/Standard for Factory-Built Grease Ducts*). Model GS is classified for continuous operation at 18 inch clearance to combustibles. Model GS grease ducts are suitable for the removal of smoke and grease laden vapors from commercial, industrial, institutional, and similar cooking applications where continuous operating temperatures are 500° F (260° C) or less and for intermittent temperatures not exceeding 2000° F (1093° C). Model GS grease ducts are intended to be part of a complete grease duct system which connects the hood or grease extractor with the outdoors by means of an exhaustor or blower system.

GENERAL INFORMATION

CLEARANCES

Clearance to non-combustible material is zero inches and the clearance to combustible material is 18 inches.

WARNING: Code compliant clearances must be followed where any components are in direct contact with the liner. Examples of this would be support assemblies, drain pipes, or any other similar items. Do not install these items near combustible material.

When installed in accordance with these instructions and codes, Model GS grease ducts are equivalent to field fabricated grease duct systems. Do not apply wraps or enclosure materials in direct contact with Van-Packer's products in a manner that adds additional weight to our duct. Model GS has not been tested, listed, designed, etc. to carry additional weight from such materials.

HOURLY RATED ENCLOSURE

Where a building is more than one story in height or for a one story building where the roof-ceiling assembly requires a fire resistance rating, the duct must be enclosed by an hourly rated enclosure. If the building is less than four stories in height, the enclosure must have a fire resistance of not less than one hour. For buildings of four stories or more, the enclosure must have a resistance rating of not less than two hours.

CODES & AUTHORITIES

Installation must be made in accordance with local and national code requirements. Follow these instructions carefully and contact local building and fire officials about restrictions and installation inspection in your area. Refer to NFPA 96 (*Standard for Ventilation Control and Fire Protection of Commercial Cooking Operations*) and additional NFPA standards as required

INSTALLATION CONSIDERATIONS

Follow Van-Packer's written installation instructions carefully. Each part of the grease duct system must be installed correctly. Improper or lack of installation of required parts may result in the improper function of the grease duct system. Always contact the technical service department with any questions.

The grease duct layout should be carefully planned to allow adequate space for assembly, installation of supports, connection of support framing, access for cleanouts, accommodate standard fitting dimensions, rough openings for penetrations, etc. Do not assume all equipment producing smoke or grease laden vapors within a facility can be exhausted with a single grease duct system. Consult a grease duct design professional as required.

One prime coat and finish coat of appropriate heat resistant paint is recommended on any non-stainless steel accessories that are in areas subject to cleaning or exposed to the weather. Stainless steel accessories are available upon special request.

GENERAL INFORMATION - CONTINUED

MIXING SYSTEMS & PARTS

Do not connect a grease duct system with any other building ventilation or exhaust system. Do not connect parts from other grease duct manufacturers with Model GS components without the expressed consent of Van-Packer.

Components from other Van-Packer product lines, (for example Model GZ, GRZ or GRS), may be mixed with Model GS components to complete a grease duct system as long as: clearances, limitations, codes, etc. are followed. Contact Van-Packer for more information concerning product lines which are listed for use as grease ducts.

Van-Packer grease duct components are designed to complete the entire system. However, we realize conditions occur where systems must be mixed. In these cases, in accordance with *good construction methods and codes* it is permissible to transition to/from a code compliant grease duct system (by others) to/from Van-Packer grease duct components. Connection must be an approved joint assembly method as described within installation instructions, and/or applicable codes. Transition (by others) cannot connect in a manner that adds additional weight/stress to our duct. Van-Packer's products have not been tested, listed, designed, etc. to carry additional weight from such transitions. **WARNING:** Listings / warranties may be affected when transitioning to / from grease ducts by others; consult Van-Packer technical service department for additional information.

DUCT SLOPE

Model GS grease ducts must be installed accordingly to comply with the requirements as described in order to maintain a listed installation. UL states that these grease ducts must comply with requirements as set forth by UL 1978 (*Standard for Grease Ducts*), NFPA 96 (*Standard for Ventilation Control and Fire Protection of Commercial Cooking Operations*), and the International Mechanical Code. Model GS grease ducts should be installed at a slope not less than 1/16 unit vertical in 12 units horizontal toward the hood or toward a grease reservoir. Where horizontal ducts exceed 75 feet in length, the slope shall be not less than 1/4 unit vertical in 12 units horizontal. Most Model GS components will permit a small amount of slope as the system is being installed. However, some installations may require elbow / transition type pieces to allow for proper orientation of fittings at the vertical risers prior to and after long horizontal runs. It is also acceptable for ducts to have staggered sloped (e.g., uphill to a peak point, then downhill to a valley point), the distance between a valley point and peak point must follow the limitations above and every valley must allow for grease drainage (i.e., a hood or reservoir). Contact Van-Packer for additional information.

CLEANOUTS, DRAINS, & GREASE TRAPS

Many Model GS sections, accessories, and combinations can be used for cleanout and inspection access of the grease duct system. Access panel sections, 90° tee sections with end caps, and many other combinations of components can serve as cleanout doors or openings as described by NFPA 96. Grease ducts must be provided with adequate cleanout doors or openings to allow for the inspection and cleaning of the entire grease duct system. Refer to NFPA 96 for specific requirements.

Cleanout, drain, and grease trap requirements may change when grease duct systems are equipped with automatic cleaning and / or some types of fire suppression equipment. Refer to NFPA 96 and additional codes / authorities having jurisdiction for specific duct system requirements.

WASH DOWN & FIRE SUPPRESSION

Automatic hot water / detergent wash down and fire suppression systems can be integrated into a Model GS grease duct system by using various components which are readily available (or by request sections can be factory fit) with threaded pipe nipples, couplings, etc.

Van-Packer does not provide, design, specify, etc. wash down and fire suppression equipment or systems. Refer to NFPA 96 and additional codes / authorities having jurisdiction for specific fire suppression system requirements. Some of the various types of fire extinguishing equipment / systems are: Carbon Dioxide (NFPA 12), Sprinkler (NFPA 13), Foam-Water (NFPA 16), and Dry Chemical (NFPA 17).

RECEIVING INSPECTION

Compare the packing list items and quantities with the contents of the containers to ensure completeness of the shipment. If the shipment is missing components, please contact Van-Packer's order entry department at 888-877-8225.

TYPICAL COMPONENT LOCATIONS

Straight sections, fittings, etc. will be positioned and stacked accordingly to fill the shipping container. Sections of smaller dimensions may be slipped into sections of larger dimensions. Bags of fasteners, sealant, etc. may also be located inside the liner of the various pieces.

FREIGHT DAMAGE

Inspect each box as it is unloaded from the carrier for damage which may have occurred during transit. Should there be any damaged components, the delivery receipt must be signed damaged in order for Van-Packer to file a claim with the carrier. If the delivery receipt is signed damaged, contact Van-Packer immediately. If there are damaged parts and the delivery receipt is not signed damaged, Van-Packer or the carrier will not be liable, and damaged parts will be replaced at the customer's expense. Do not return any parts to the factory without prior authorization from Van-Packer Company

PART IDENTIFICATION & MATERIAL CODES

Model GS part numbers will typically have the letter "GS" prefix, followed by the duct diameter (I.D.), then the part description code, next a special qualifier code(s) and last the liner material designation. Part description codes are generally three characters and are either alpha or alpha numeric. Qualifier codes are most often used to designate section lengths, tee projection dimensions, and the large I.D. end of increasers. The following are a couple examples of part numbers with their associated description and part number breakdown.

GS12STR30A

Refers to a Model GS 12" I.D., 30" long straight section constructed with a 304 S.S. liner.

GS = Model GS
12 = Section I.D.
STR = Part Code, Straight Section
30 = Section length, 30" long
A = Liner Material Code, 304 S.S.

GS1290T08B

Refers to a Model GS 12" I.D. 90 degree centered tee section with an 08" I.D. projection constructed with a 316 S.S. liner.

GS = Model GS
12 = Tee Body, 12" I.D.
90T = Part Code, 90 Degree Tee Section
08 = Tee Projection, 08" I.D.
B = Liner Material Code, 316 S.S

LINER MATERIAL CODES

A = 304 S.S.
B = 316 S.S.

JOINT ASSEMBLY

According to NFPA 96, all grease ducts are to be liquid tight. The following steps are to be used to ensure this requirement is met.

Use high temperature silicone sealant, Van-Packer part number 101087A. **WARNING:** Do not substitute any type of water soluble sealants in the flange area.

STEP 1

Inspect all liner flanges and straighten any mild deformations that may have occurred during shipping.

STEP 2

To ensure sealant adhesion, degrease and remove any dirt and debris from the liner flanges. Use an acetone based cleaner applied to a rag.

STEP 3

Apply a continuous bead of sealant (1/8" to 1/4") to one or both of the liner flanges to be joined.

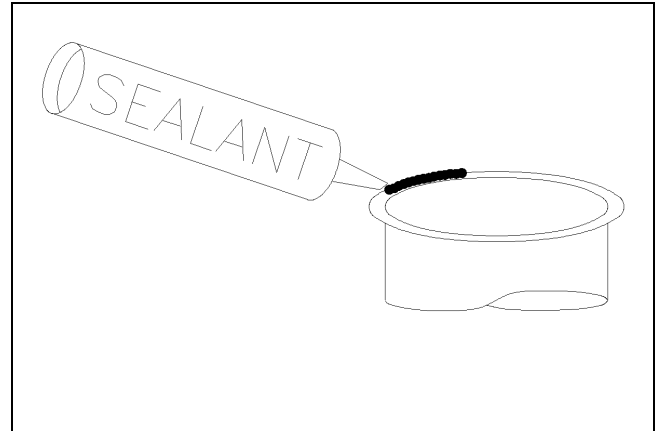

STEP 4

Butt the flanged ends of the sections being joined, being careful not to smear off the sealant. Re-apply if this happens.

Apply a bead of sealant into the groove of the vee band. It is **necessary** to lightly tap the vee band while tightening, this will ensure a snug fit.

Wipe smooth any excess sealant on the inside of the assembled duct to prevent sealant dams.

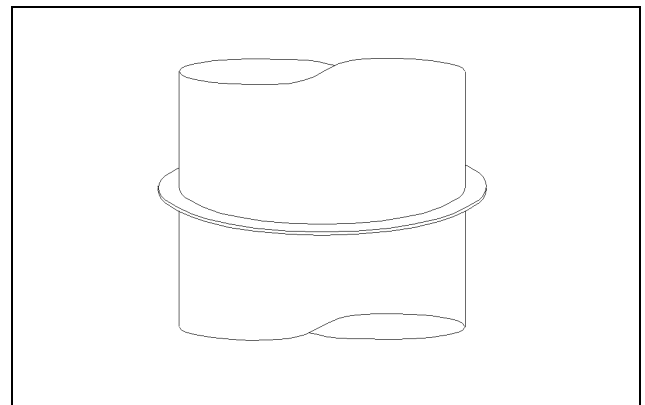

Allow sealant to cure 72 hours before use. Sealant will not bond to flanges if moisture is introduced into system before sealant has cured.

Failure to follow our instructions could lead to leaking joints.

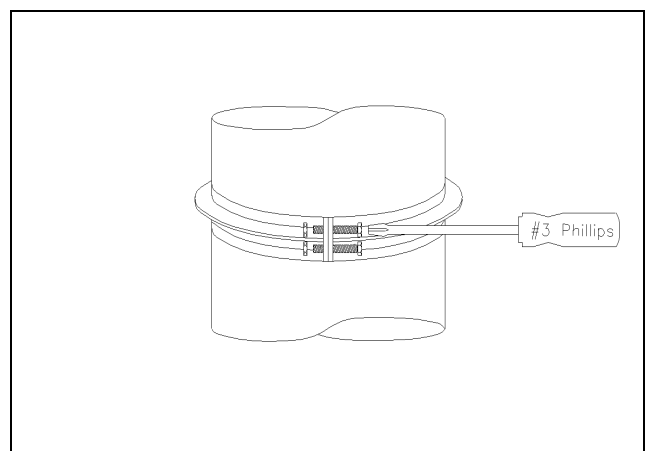

APPROXIMATE SEALANT USAGE

Section I.D.	6"	7"	8"	9"	10"	12"	14"-16"	18"-20"	22"-30"	32"-38"	40"-48"
Joints per Tube	12	10	9	8	7	6	5	4	3	2	1

APPROXIMATE INSTALLED WEIGHT

Inside Diameter	Lbs/Ft
6"	3
7"	3
8"	4
9"	4
10"	5
12"	6
14"	6
16"	7

Inside Diameter	Lbs/Ft
18"	8
20"	9
22"	10
24"	11
26"	12
28"	12
30"	13
32"	14

Inside Diameter	Lbs/Ft
34"	15
36"	16
38"	22
40"	23
42"	24
44"	25
46"	26
48"	27

APPROXIMATE HEIGHT LIMITATIONS in Feet

Inside Dia	STR	TEE	PLS	WSA
6"	625	209	788	486
7"	562	200	706	424
8"	512	193	643	375
9"	473	188	593	337
10"	441	184	553	306
12"	385	174	481	253
14"	351	169	422	219
16"	321	164	371	191
18"	301	143	336	171
20"	281	126	304	153
22"	269	112	281	140
24"	255	100	259	128

Inside Dia	STR	TEE	PLS	WSA
26"	246	84	243	119
28"	239	69	229	111
30"	230	57	215	103
32"	224	46	205	97
34"	217	36	194	87
36"	213	27	186	80
38"	161	21	135	55
40"	160	21	129	50
42"	160	20	125	45
44"	159	20	120	41
46"	159	20	116	38
48"	158	20	112	34

DUCT SECTIONS & FITTINGS

Van-Packer makes a wide range of prefabricated adapters, fittings, elbows, wyes, tees, transitions, increasers, terminations, etc. Refer to the Model GS brochure for additional information on part number designations and the wide range of parts and fittings we offer to complete a system from start to finish. In general, all sections are assembled with a standard flange connection; however, below are a few examples of parts that may require special attention.

ADAPTERS

Adapters connect to the liner flange per the joint assembly instructions.

FAN/HOOD - PART FAS is intended to be used with a roof curb (provided by others) connection to a hood or an exhaust fan. Field connect the plate to the hood, curb or fan (drilling / fasteners & sealant by others as required). Refer to the hood, fan unit or the roof curb manufacturer's installation requirements.

STARTER SECTION - PART S/S is a short liner piece flanged on each end. This part is intended to have one end connected to a hood, duct/transition, fan unit, etc.

FLANGELESS OUTLET ADAPTER - PART FOA is a split liner piece with draw-up tabs. This adapter is intended to be slipped over a smooth collar, then drawn tight with the included fasteners.

BOLT FLANGE - PART BFA is a short liner piece flanged on each end with a preassembled 1/4" thick van-stone (free floating) type bolt flange. This adapter is intended to be connected to a companion flange with appropriate fasteners (fasteners by others).

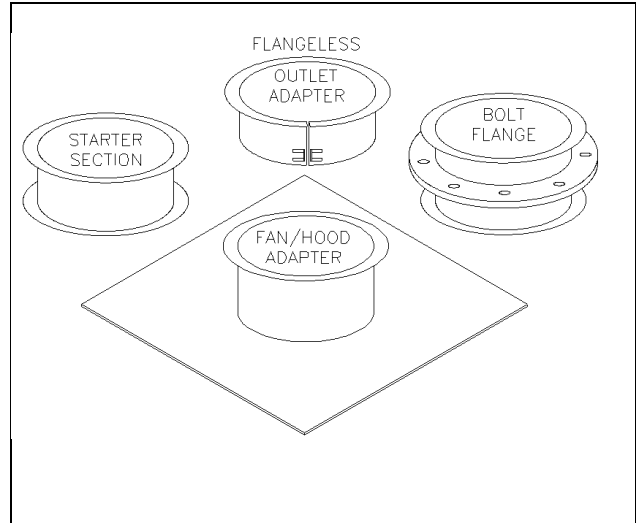

FITTINGS & STRAIGHT SECTIONS

Fittings and Straight sections are fixed degrees, lengths, etc., joined together to complete desired grease duct runs. These sections may also be equipped (must be factory installed) with nipples or couplings to accommodate test probes, fire suppression nozzles, sprinkler heads, drainage, etc. Refer to the Model GS brochure for designation of part lengths and options for adding pipe nipples / couplings.

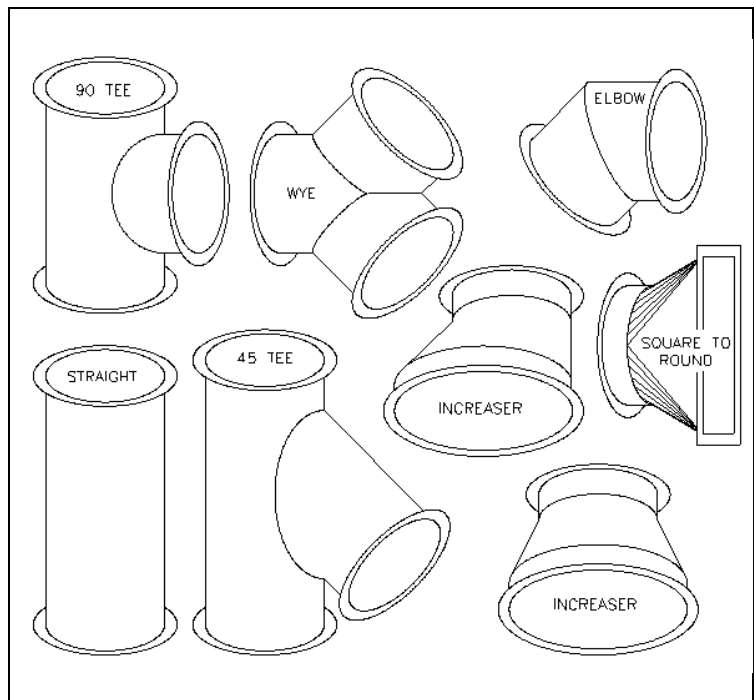

DUCT SECTIONS & FITTINGS CONTINUED

ACCESS PANEL & GREASE DRAINS

These parts are intended to be used for accessing, cleaning, and draining. Some uses for these fitting are: duct access, test probes, sprinkler heads, fire suppression nozzles, grease drainage, etc. Please refer to the Model GS brochure for additional information and part number designation.

NOTE: When the access panel section is installed in a horizontal position, it must be orientated in accordance with applicable codes.

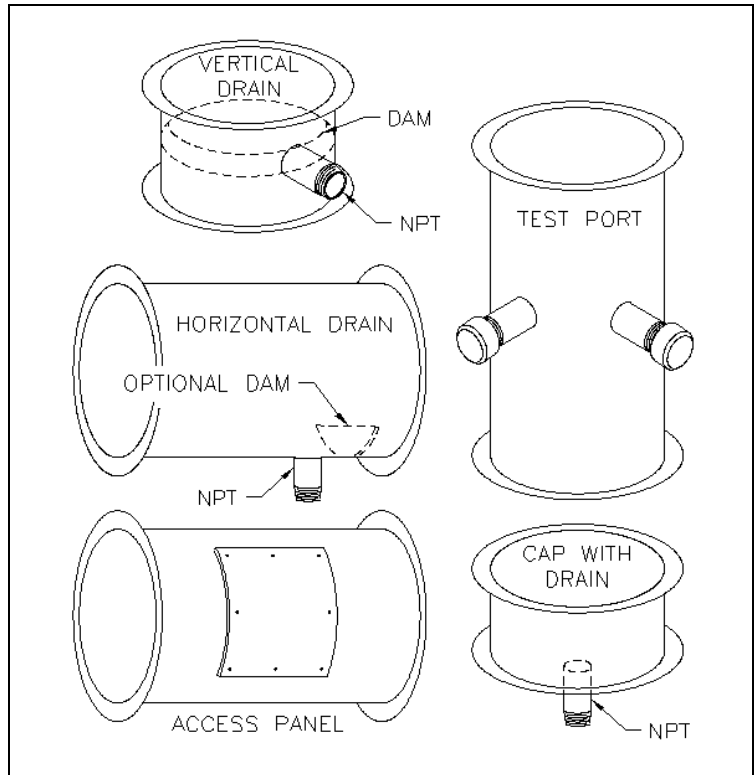

TERMINATIONS

Terminations connect to the liner flange per the joint assembly instructions. Van-Packer makes several terminations. Refer to the Model GS brochure for additional information on part number designations and the wide range of parts we offer to complete a system.

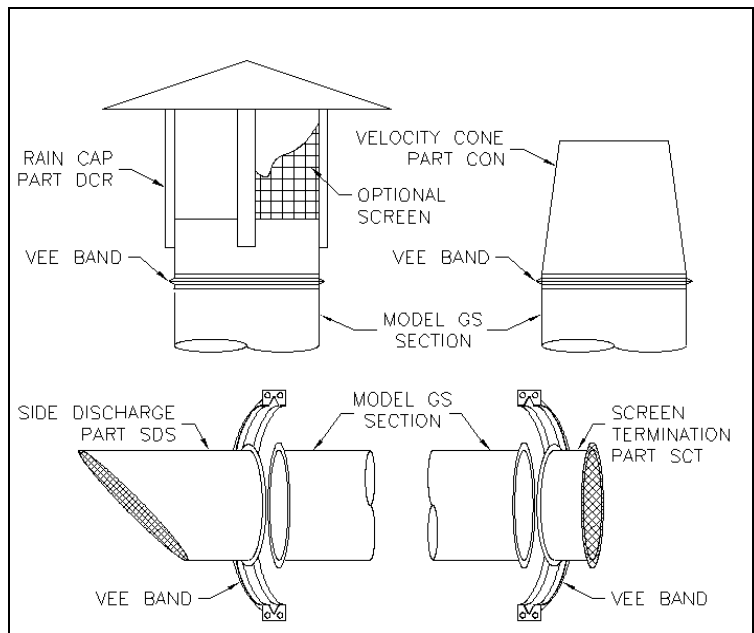

DUCT SECTIONS & FITTINGS - CONTINUED

ADJUSTABLE EXPANSION AND VARIABLE LENGTH SECTIONS

These components cannot be installed in series and are non-load bearing. For some installations, I.E. between two fittings, field cutting of the slip liner may be required. The raw end of the slip liner must slide into the mating section a minimum of 2", more is better. The raw end must always be down-hill from the rolled flange end. Do not cut slip liners to the exact "flange to flange" distance of the components being joined. Carefully cut and position slip liners accordingly when installed near tee sections, elbows, etc. as to not restrict/obstruct the flow of the duct system.

NOTE: Apply sealant per the pictures to the right and the joint assembly instructions. Slide the slip liner into the previous installed section before installing the following sections. On the variable length section remember to slide the locking collar on the slip liner before sliding it into the previous section.

PART – ADJ

Adjustable expansion section is intended to be used to span distances between 1-1/2" to 19-1/2" and compensates for thermal expansion. These components are comprised of a slip liner and rope gasket.

PART – VLS

Variable length sections are intended to be used to span distances between 4-1/2" to 19-1/2". These components are comprised of a slip liner and locking collar. This part simulates a custom length straight section.

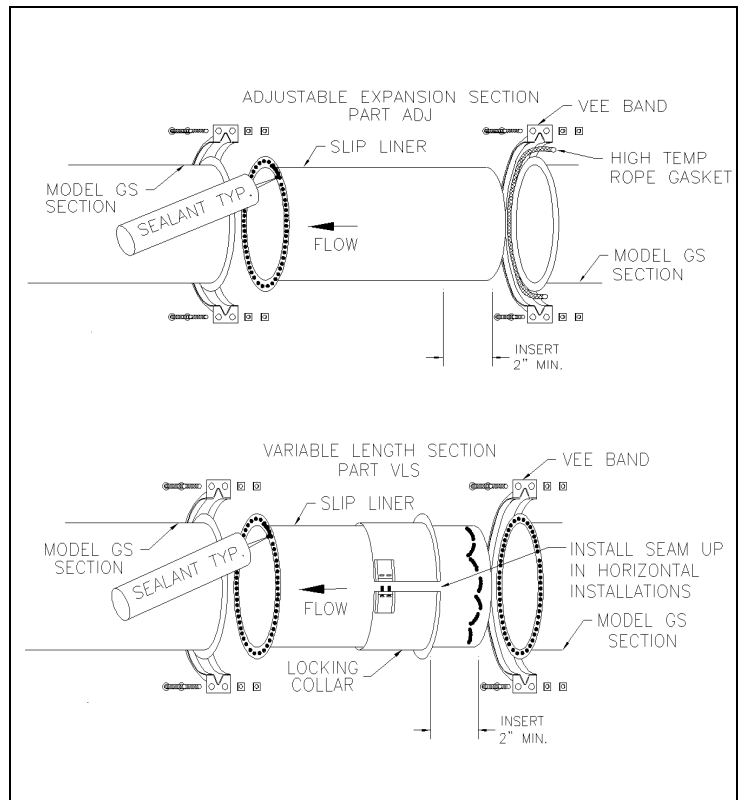

SUPPORTS & GUIDES

NOTES: The structural engineer for the project should select support member channels, beams, rods, wires/cables, etc. and joining methods in accordance with *Good Engineering Practices* to suite each specific application. Rods, wires/cables should only be used for hangers, NOT structural supports. Van-Packer accepts no responsibility for the design and/or modification of buildings or structures to accept the given load. All support framing, anchoring methods, etc. are by others.

STRUCTURAL SUPPORTS

PLATE SUPPORT ASSEMBLY – PART PLS

Plate support assemblies are used for vertical & horizontal structural anchor points. The PLS is to be used with structural support members, which are designed by the building structural engineer, not Van-Packer. Refer to page 7 for structural support limitations.

NOTE

The PLS consists of 4 pieces, 2 rectangular support plates and 2 round clamp flange halves. The PLS, in conjunction with field fabricated support members, provides support for the duct (The seam in the S/P must be rotated 90 degrees from the C/F seam)

STEP 1

Apply sealant on the liner flange. Join the two liners together (no Vee Band is required) to capture the flanges between the support plate and the clamp flange. Bolt together the S/P and the C/F with the 3/8" bolts provided. Fully tighten the bolts.

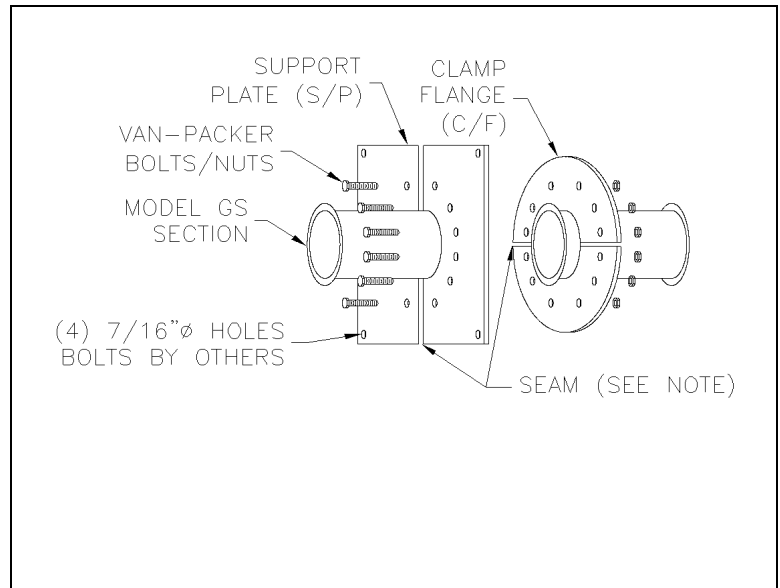

STEP 2

Support all four sides of the support plate. Design support member and fasteners in accordance with good engineering practices to suit each specific application. Van-Packer assumes no responsibility for the design and/or modification of buildings or structures to accept the given loads

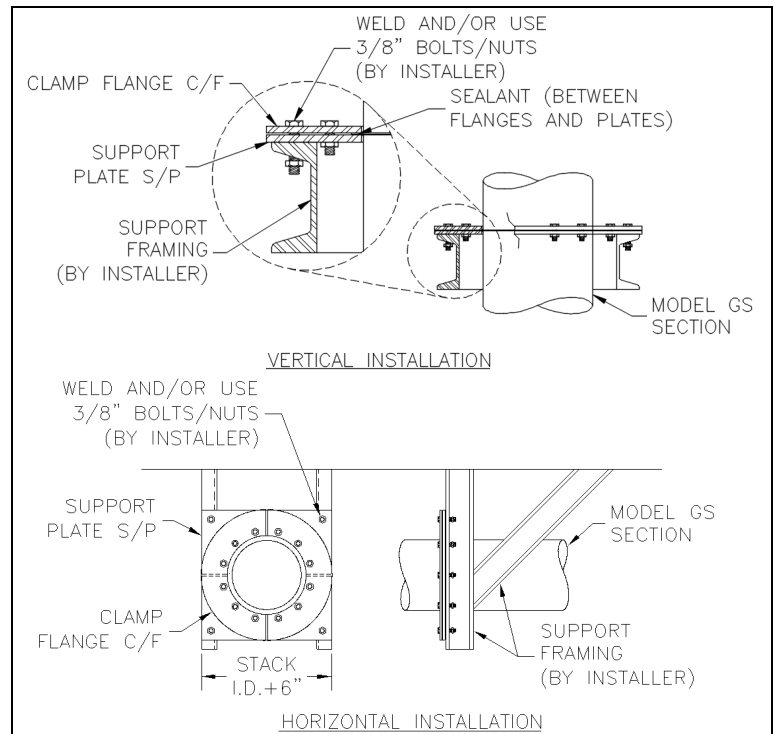

SUPPORTS & GUIDES - CONTINUED

WALL SUPPORT – PART WSA

The wall support (WSA) is intended to provide a rigid support location. In some instances, additional field fabricated support members from the building wall structure to the wall bracket may be required. Anchor bolts and design by others. This rigid support location is intended to withstand the weight of duct components, forces from thermal expansion & exhaust velocities, etc. Design support member and fasteners in accordance with good engineering practices to suit each specific application. Van-Packer assumes no responsibility for the design and/or modification of buildings or structures to accept the given loads. Do not install near combustible material. Refer to chart on page 7 for support limitations.

NOTE:

The WSA consists of 6 pieces, 2 wall brackets, (left and right), 2 bottom plates and 2 top plates.

STEP 1

Apply sealant on the liner flange. Join the two liners together (no Vee Band is required) to capture the flanges between the top and bottom plates. Bolt together the top and bottom plates with the 3/8" bolts provided. Fully tighten the bolts. These plates install just like the plate support assembly (page 11)

STEP 2

Anchor the wall brackets to the wall or additional field fabricated support members accordingly.

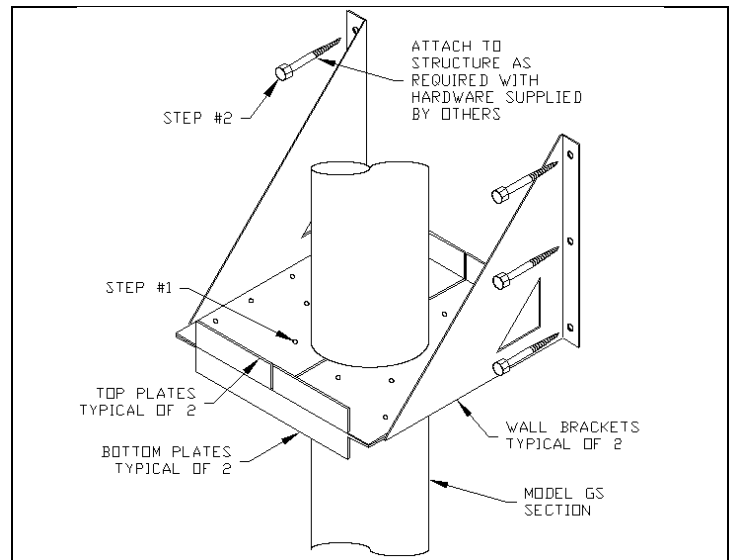

HORIZONTAL SUPPORT HANGER

HANGER SUPPORTS

Van-Packer offers a few options for Horizontal Hanger Supports. They support the weight of horizontal assembled duct lengths while also maintaining alignment as the duct expands and contracts. Use hangers in conjunction with support rods or other field fabricated support members that attach to the building or structure. Position hanger away from joint to allow for unrestricted expansion and contraction of the duct system.

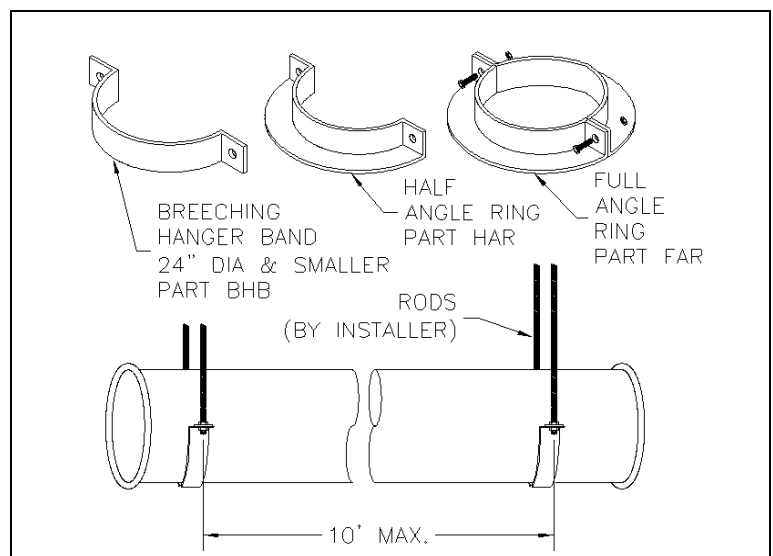

SUPPORTS & GUIDES - CONTINUED

LATERAL BRACES

FULL ANGLE RING – PART FAR

Full angle ring, in conjunction with field fabricated support members from the FAR attached to the building or structure, are intended to laterally brace the vertical assembled duct lengths from wind loads and to also maintain alignment. The FAR is comprised of (2) halves when bolted together fit loose around the duct to allow for expansion and contractions. Position the FAR away from the joint to allow for unrestricted expansion and contraction of the duct system.

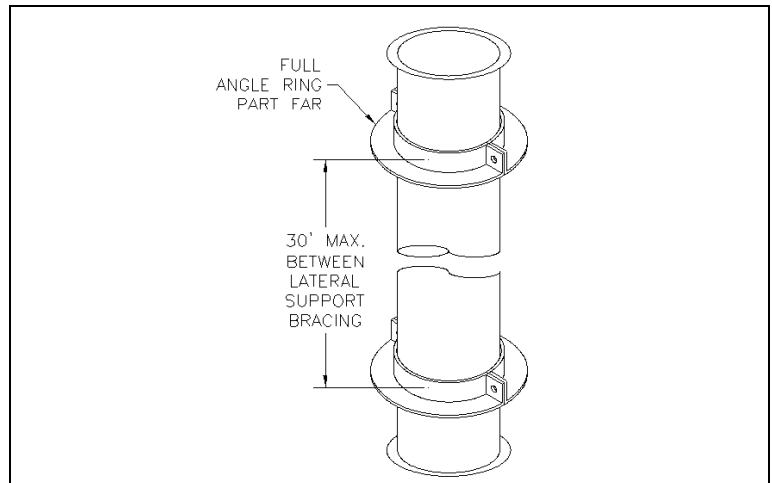

GUY ATTACHMENT RING – PART GAR

Guy attachment ring, in conjunction with cables, tensioners, anchors, and other miscellaneous hardware from the GAR attached to the building structure, are intended to laterally brace the vertical assembled duct lengths from wind loads and to also maintain alignment as the duct expands and contracts.

NOTE

The GAR consists of 4 clamp flanges (Do NOT line up seams of the clamp flanges. They should be rotated by 90 deg). Minimum of three cables spaced at 120 deg apart is required for one GAR. Cables, anchors and all other miscellaneous hardware is by installing contractor. Please note the cables must have tension on them at all times. (Do not over tension the wires) Some type of a tensioner must be used to keep the cables tight while still allowing for expansion and contraction

STEP 1

Apply sealant on the liner flange. Join the two liners together (no Vee Band is required) to capture the flanges between the clamp flanges. Bolt together the flanges with the 3/8" bolts provided. Fully tighten the bolts

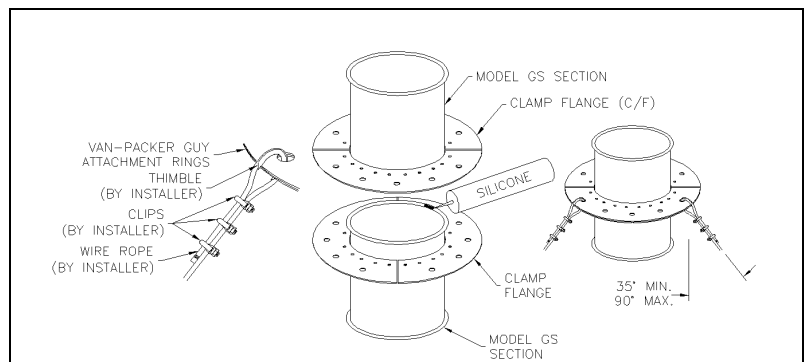

GUY TENSIONER – PART 1500GUY

Van-Packer offers a 1500 pound Guy Tensioner that is good for up to 3" of expansion. Use the guy tensioner in conjunction with the guy attachment ring. The guy tensioner allows you to keep tension on the guy cables while still allowing for expansion and contraction. Cables, anchors, and other miscellaneous hardware is to be by the installing contractor. (Do not over tension the wires)

NOTE: Van-Packer accepts no responsibility for the design and/or modification of buildings or structures to accept the given load.

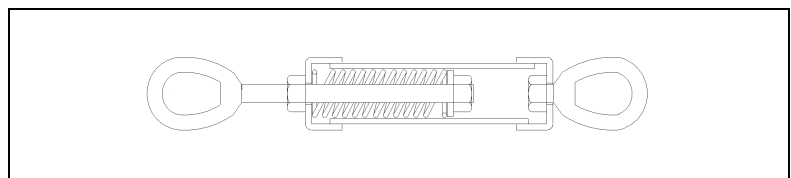

PENETRATIONS FLOORS/CEILINGS & WALLS - FIRE RATING NOT REQUIRED

FINISHING PLATE - PART FPL

The finishing plate can be used when the duct passes through a floor/ceiling or wall where a fire rating is not required. The minimum rough opening (square or round opening allowed) must be enough to allow the duct to pass through, approximately duct O.D. +2". The maximum rough opening is duct O.D. +8" (Max. opening size when duct is centered through the opening). The FPL includes (1) plate assembly. Please note two plate assemblies shown below in the picture.

Cut the rough opening accordingly and assemble the duct through. Position the plate halves (allow slight clearance to the duct O.D. to accommodate any expansion as needed). Anchor the plates with appropriate fasteners (by others) at hole locations. Do not locate joint near finishing plate (FPL). Must allow for unrestricted expansion and contraction of the duct system.

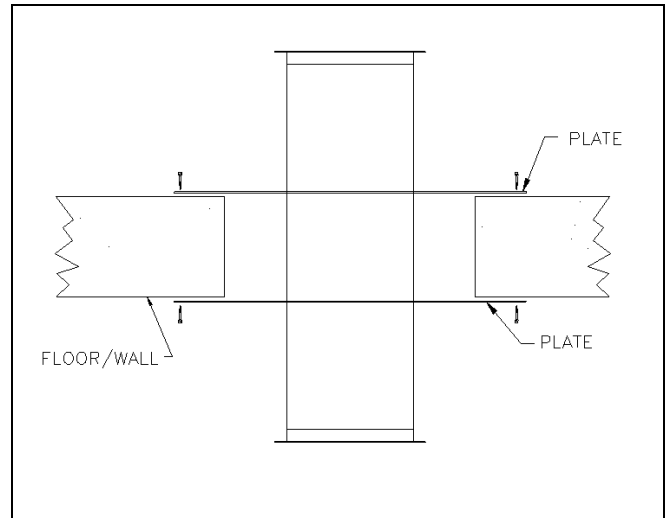

ROOF PENETRATION

FLASHING & COUNTER FLASHING - PARTS FLS & CFL

The flashing and counter flashing can be used when the duct passes through a non-combustible roof or curb. Pitched flashings are available upon special request. The minimum rough opening (square or round opening allowed) must be enough to allow the duct to pass through, approximately duct O.D. +4". The maximum recommended rough opening is duct O.D. +12" (reflects flat roof only with the duct centered through opening).

STEP 1

Cut the rough roof opening. Center the flashing around the opening and with appropriate fasteners attach it to the roof. Roofing materials to complete a weather tight seal should be installed over the square base of the flashing. (**Note:** Consult the roofing contractor)

STEP 2

Assemble the duct through the flashing accordingly. Next, install the counter flashing by positioning it around the duct and against the screen at the top of the flashing. Then, with the provided fasteners draw up the counter flashing. Last, apply a bead of sealant at the seam of the counter flashing and duct. **Notes:** Always clean any parts with acetone before applying sealant. Roofing materials must not fill the entire space between the roof and the bottom of the counter flashing.

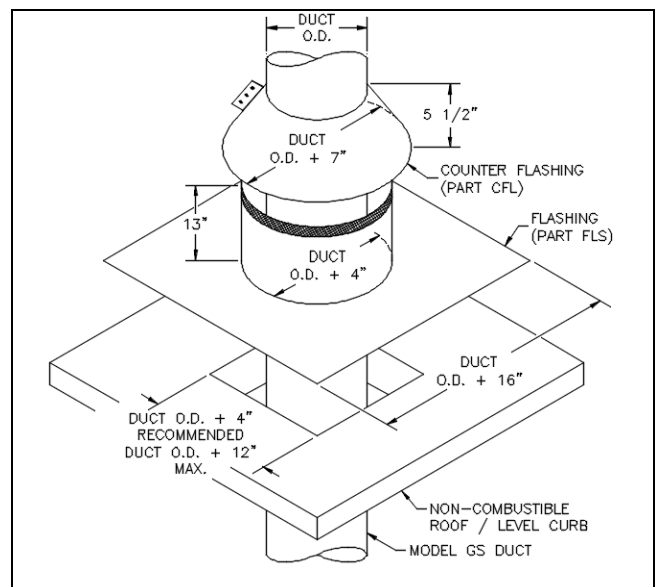

SYSTEM INSTALLATION EXAMPLE

Below shows an installation example. This example is intended to reflect general requirements for support locations, with respect to fittings and to also show standard supports locations for an installation in accordance with its design listing. This example may not reflect all necessary cleanouts, drains, etc. which may be required to meet applicable codes and to help ensure a well functioning grease duct system (refer to applicable codes as required).

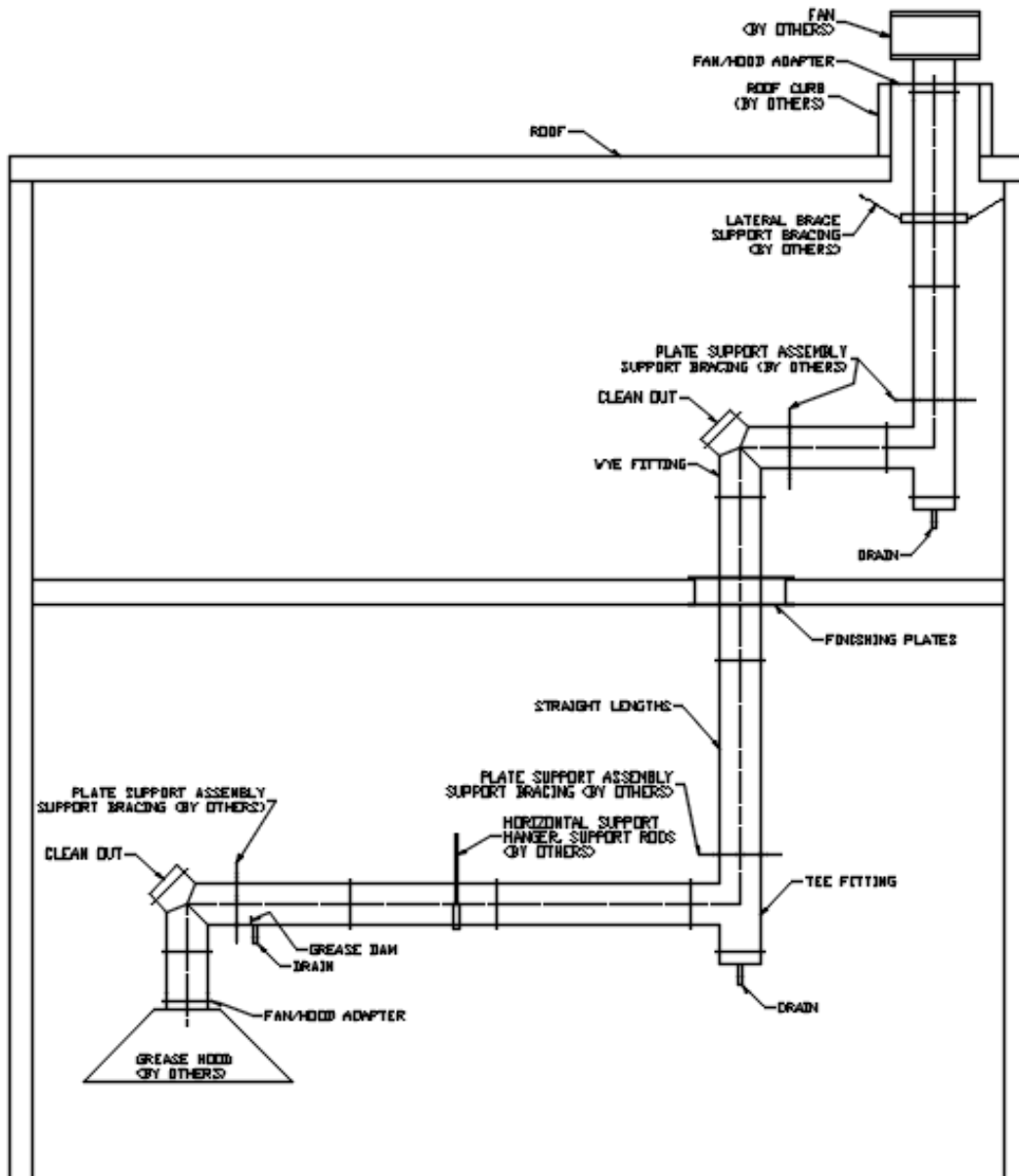

Van-Packer Company
Sales, Service and Manufacturing
302 Mill Street, PO Box 307
Buda, Illinois 61314-0302
Phone 1-888-VPSTACK (1-888-877-8225) or 1-309-895-2311
Fax 1-309-895-3891
Tech Email vpstech@vpstack.com
Web Site www.vpstack.com

GS Installation Guidelines 08/10/21