

MODEL GRM SERIES

GRA=(Double Wall Rectangular Grease Duct, 3" & 4" Air Insulated GR_A)

GR+=(Double Wall Rectangular Grease Duct, 3" & 4" Mineral Wool Insulation, GR_+)

GRC=(Double Wall Rectangular Grease Duct, 3" & 4" Ceramic Insulation, GR_C)

Installation Guidelines

Tested to: UL 1978 / ULC S662



TABLE OF CONTENTS

LISTING & CODE COMPLIANCE	3
TESTING, CLASSIFICATION, & APPLICATIONS.	3
CLEARANCES TO COMBUSTIBLES.	3
GENERAL INFORMATION	3-5
WARNING	3
HOURLY RATED ENCLOSURE	4
CODES & AUTHORITIES.	4
INSTALLATION CONSIDERATIONS	4
MIXING SYSTEMS & PARTS.	4
DUCT SLOPE.	4
CLEANOUTS, DRAINS & GREASE TRAPS	5
WASH DOWN & FIRE SUPPRESSION	5
APPLICATIONS	5
RECEIVING INSPECTION	5
TYPICAL COMPONENT LOCATIONS	5
FREIGHT DAMAGE.	5
PART IDENTIFICATION & MATERIAL CODES	6
JOINT ASSEMBLY	7
FLANGE / DRAW BAND FASTENERS	8
INSULATION	8
SEALANT USAGE	8
INSTALLED WEIGHT CHART.	8-9
SUPPORT LIMITATIONS.	9
DUCT SECTIONS & FITTINGS	10-11
FAN/HOOD ADAPTER ASSEMBLY	10
FITTINGS & STRAIGHT SECTIONS	10
ACCESS PANEL SECTION	10
OPEN TOP CLOSURE	11
RAIN CAP	11
SUPPORTS & GUIDES.	12-14
PLATE SUPPORT.	12
FLANGE SUPPORT	13
WALL BRACKETS	13
HORIZONTAL SUPPORT HANGERS	14
LATERAL BRACES & GUIDES.	14
GUY ATTACHMENT PLATE	14
PENETRATIONS	15
FLOOR/CEILING & WALLS.	15
ROOF PENETRATIONS	15
SYSTEM INSTALLATION EXAMPLE.	16

WARNING

Major causes of grease duct fires are failure to maintain required clearance to combustibles and failure to clean and remove grease build-up from the duct system. In the event of a grease fire (due to failure to clean the duct in accordance with code) the grease duct must be replaced. It is important to read and understand these instructions fully before installing this grease duct system. Failure to comply with these instructions will result in a hazardous installation and will void the warranty.

STANDARD WARRANTY

When this system, provided by the Van-Packer Company, is installed per these instructions, we warrant the parts to be free from defects in material and workmanship for a period of 12 months from the date of shipment. For warranty questions please contact the technical service department for further details and stipulations.

LISTING & CODE COMPLIANCE

Van-Packer's GRM Series grease duct is listed by UL as "2 to 17 inch clearance to combustibles (see chart below) grease duct assembly" and as "Grease Ducts for Restaurant Cooking Appliances" when installed in accordance with these instructions and the National Fire Protection Association's standard NFPA 96 "Standard for Ventilation Control and Fire Protection of Commercial Cooking Operations," International Mechanical Code, Uniform Mechanical Code, or other local codes.

TESTING, CLASSIFICATION, & APPLICATIONS

GRM Series has been tested in accordance with the procedures and methods set forth by UL 1978/ULC S662 (Standard for Grease Ducts/Standard for Factory-Built Grease Ducts).

GRM Series Grease Ducts are rated for:

1. Continuous operation at 2 to 17 inch clearance to combustibles (see chart below).
2. Continuous operation at zero inch clearance to non-combustibles.
3. Removal of smoke and grease laden vapors from commercial, industrial, etc. cooking applications.
4. Continuous operating temperatures are 500° F (260° C) or less and for intermittent temperatures not exceeding 2000° F (1093° C).
5. Venting negative, neutral, and positive pressure applications.
6. Positive pressures up to 60 inches water column.

GRM Series grease ducts are intended to be part of a complete grease duct system which connects the hood or grease extractor with the outdoors by means of an exhaustor or blower system.

CLEARANCE TO COMBUSTIBLES

Model GR_A 3" & 4" Air Space	
Duct Area* sq"	Clearance
36 – 78	8" (203 mm)
>78 – 113	9" (229 mm)
>113 – 254	10" (254 mm)
>254 – 380	11" (279 mm)
>380 – 615	12" (305 mm)
>615 – 804	13" (330 mm)
>804 – 1017	14" (356 mm)
>1017 – 1256	15" (381 mm)
>1256 – 1520	16" (406 mm)
>1520 – 2304	17" (432 mm)

Model GR_ _ 3" or 4" Insulation Space	
Duct Area* sq"	Clearance
36 – 113	2" (51 mm)
>113 – 254	3" (76 mm)
>254 – 314	4" (102 mm)
>314 – 530	5" (127 mm)
>530 – 804	6" (152 mm)
>804 – 1017	7" (178 mm)
>1017 – 1256	8" (203 mm)
>1256 – 2304	9" (229 mm)

*Duct area is in square inches and based on the liner inside dimensions, width x height. Example, a duct 6" x 10" has an area of 60 square inches.

GENERAL INFORMATION

WARNING: Code compliant clearances must be followed where any components are in direct contact with the liner. Examples of this would be support assemblies, drain pipes, or any other similar items. Do not install these items near combustible material.

When installed in accordance with these instructions and codes, GRM Series grease ducts are equivalent to field fabricated grease duct systems. Do not apply wraps or enclosure materials in direct contact with Van-Packer's products in a manner that adds additional weight to our duct. GRM Series has not been tested, listed, designed, etc. to carry additional weight from such materials.

GENERAL INFORMATION - CONTINUED

HOURLY RATED ENCLOSURE

Where a building is more than one story in height or for a one story building where the roof-ceiling assembly requires a fire resistance rating, the duct must be enclosed by an hourly rated enclosure. If the building is less than four stories in height, the enclosure must have a fire resistance of not less than one hour. For buildings of four stories or more, the enclosure must have a resistance rating of not less than two hours.

CODES & AUTHORITIES

Installation must be made in accordance with local and national code requirements. Follow these instructions carefully and contact local building and fire officials about restrictions and installation inspection in your area. Refer to NFPA 96 (*Standard for Ventilation Control and Fire Protection of Commercial Cooking Operations*) and additional NFPA standards as required.

INSTALLATION CONSIDERATIONS

Follow Van-Packer's written installation instructions carefully. Each part of the grease duct system must be installed correctly. Improper or lack of installation of required parts may result in the improper function of the grease duct system. Always contact the technical service department with any questions.

The grease duct layout should be carefully planned to allow adequate space for assembly, installation of supports, connection of support framing, access for cleanouts, accommodate standard fitting dimensions, rough openings for penetrations, etc. Do not assume all equipment producing smoke or grease laden vapors within a facility can be exhausted with a single grease duct system. Consult a grease duct design professional as required.

Paint is recommended on any non-stainless steel components that are in areas subject to cleaning or exposed to the weather. Paint in accordance with paint manufactures recommendations. Stainless steel accessories are available upon special request.

MIXING SYSTEMS & PARTS

Do not connect a grease duct system with any other building ventilation or exhaust system. Do not connect parts from other grease duct manufacturers with GRM Series components without the expressed consent of Van-Packer.

Components from other Van-Packer product lines, (for example Model GA, GZ, GRZ, GS or GRS), may be mixed with GRM Series components to complete a grease duct system as long as: clearances, limitations, codes, etc. are followed. Contact Van-Packer for more information concerning product lines which are listed for use as grease ducts.

Van-Packer grease duct components are designed to complete the entire system. However, we realize conditions occur where systems must be mixed. In these cases, in accordance with *good construction methods and codes* it is permissible to transition to/from a code compliant grease duct system (by others) to/from Van-Packer grease duct components. Connection must be an approved joint assembly method as described within installation instructions, and/or applicable codes. Transition (by others) cannot connect in a manner that adds additional weight/stress to our duct. Van-Packer's products have not been tested, listed, designed, etc. to carry additional weight from such transitions. **WARNING:** Listings / warranties may be affected when transitioning to / from grease ducts by others; consult Van-Packer Technical Service Department for additional information.

DUCT SLOPE

Model GRM grease ducts must be installed accordingly to comply with the requirements as described in order to maintain a listed installation. UL states that these grease ducts must comply with requirements as set forth by UL 1978 (*Standard for Grease Ducts*), NFPA 96 (*Standard for Ventilation Control and Fire Protection of Commercial Cooking Operations*), and the International Mechanical Code. Model GRM grease ducts should be installed at a slope not less than 1/8 unit vertical in 12 units horizontal toward the hood or toward a grease reservoir. Where horizontal ducts exceed 75 feet in length, the slope shall be not less than 1/4 unit vertical in 12 units horizontal. Most Model GRM components will permit a small amount of slope as the system is being installed. However, some installations may require elbow / transition type pieces to allow for proper orientation of fittings at the vertical risers prior to and after long horizontal runs. It is also acceptable for ducts to have staggered sloped (e.g., uphill to a peak point, then downhill to a valley point), the distance between a valley point and peak point must follow the limitations above and every valley must allow for grease drainage (i.e., a hood or reservoir). Contact Van-Packer for additional information.

GENERAL INFORMATION - CONTINUED

CLEANOUTS, DRAINS, & GREASE TRAPS

Many GRM Series sections, accessories, and combinations can be used for cleanout and inspection access of the grease duct system. Access panel sections, 90° tee sections with end caps, and many other combinations of components can serve as cleanout doors or openings as described by NFPA 96. Grease ducts must be provided with adequate cleanout doors or openings to allow for the inspection and cleaning of the entire grease duct system. Refer to NFPA 96 for specific requirements.

Cleanout, drain, and grease trap requirements may change when grease duct systems are equipped with automatic cleaning and / or some types of fire suppression equipment. Refer to NFPA 96 and additional codes / authorities having jurisdiction for specific duct system requirements.

WASH DOWN & FIRE SUPPRESSION

Automatic hot water / detergent wash down and fire suppression systems can be integrated into a GRM Series grease duct system by using various components which are readily available (or by request sections can be factory fit) with threaded pipe nipples, couplings, etc.

Van-Packer does not provide, design, specify, etc. wash down and fire suppression equipment or systems. Refer to NFPA 96 and additional codes / authorities having jurisdiction for specific fire suppression system requirements. Some of the various types of fire extinguishing equipment / systems are: Carbon Dioxide (NFPA 12), Sprinkler (NFPA 13), Foam-Water (NFPA 16), and Dry Chemical (NFPA 17).

APPLICATIONS

GRM Series grease duct is suitable for interior or exterior installations. Suitable for the removal of smoke and grease laden vapors from commercial, industrial, institutional, and similar cooking applications. GRM Series duct systems have various components which are readily available for your venting needs. Always contact Van-Packer for additional uses and information, refer to NFPA 96 and additional codes / authorities having jurisdiction for specific grease duct system requirements.

RECEIVING INSPECTION

Compare the packing list items and quantities with the contents of the containers to ensure completeness of the shipment. If the shipment is missing components, please contact Van-Packer's order entry department at 888-877-8225.

TYPICAL COMPONENT LOCATIONS

Straight sections, fittings, etc. will be positioned and stacked accordingly to fill the shipping container. Sections of smaller dimensions may be slipped into sections of larger dimensions. Bags of fasteners, sealant, etc. may also be located inside the liner of the various pieces.

FREIGHT DAMAGE

Inspect each box as it is unloaded from the carrier for damage which may have occurred during transit. Should there be any damaged components, the delivery receipt must be signed damaged in order for Van-Packer to file a claim with the carrier. If the delivery receipt is signed damaged, contact Van-Packer immediately. If there are damaged parts and the delivery receipt is not signed damaged, Van-Packer or the carrier will not be liable, and damaged parts will be replaced at the customer's expense. Do not return any parts to the factory without prior authorization from Van-Packer Company.

PART IDENTIFICATION & MATERIAL CODES

GRM Series part numbers will start with the letter “GR” prefix, followed by the air or insulation type and thickness (if applicable) followed by the duct dimensions (I.D.), then the part description code, next a special qualifier code (if applicable) and last the liner/shell material designation. Part description codes are generally three characters and are either alpha or alpha numeric. Qualifier codes are most often used to designate section lengths, tee projection dimensions, and the large I.D. end of increasers. The following are a few examples of part numbers with their associated description and part number breakdown.

GR3A12X10STR30AL

Refers to GRM Series, with 3” air space, 12” x 10” I.D., 30” long straight section constructed with a 304 S.S. liner and an aluminized steel shell.

GR3A = Model GRA, with 3” air space
12x10 = Section Inside Dimension, 12” x 10”
STR = Part Code, Straight Section
30 = Section length, 30” long
A = Liner Material Code, 304 S.S.
L = Shell Material Code, ALZD Steel

GR4A12X1290T08X08AC

Refers to GRM Series, with 4” air space, 12” x 12” I.D. 90 degree centered tee section with an 8” x 8” I.D. projection constructed with a 304 S.S. liner and a 430 S.S. shell.

GR4A = Model GRA, with 4” air space
12x12 = Tee Body, 12” x 12” Inside Dimension
90T = Part Code, 90 Degree Tee Section
08x08 = Tee Projection, 8” x 8” Inside Dimension
A = Liner Material Code, 304 S.S.
C = Shell Material Code, 430 S.S.

GR3+12X1290T08X08AL

Refers to GRM Series, with 3” Mineral Wool insulation, 12” x 12” I.D. 90 degree centered tee section with an 8” x 8” I.D. projection constructed with a 304 S.S. liner and an aluminized steel shell.

GR3+ = Model GRplus, with 3” Mineral Wool insulation
12x12 = Tee Body, 12” x 12” Inside Dimension
90T = Part Code, 90 Degree Tee Section
08x08 = Tee Projection, 8” x 8” Inside Dimension
A = Liner Material Code, 304 S.S.
L = Shell Material Code, ALZD Steel

GR4+12X0845EAC

Refers to a GRM Series, with 4” Mineral Wool insulation, 12” x 8” I.D. 45 degree elbow constructed with a 304 S.S. liner and 430 S.S. shell.

GR4C = Model GRplus, with 4” Mineral Wool insulation
12x08 = Section Inside Dimension, 12” x 8”
45E = Part Code, 45 degree Elbow
A = Liner Material Code, 304 S.S.
C = Shell Material Code, 430 S.S.

LINER MATERIAL CODES *

A = 304 S.S.

SHELL MATERIAL CODES *

C = 430 S.S.
L = Aluminized Steel

* 304/ALZD and 304/430 are standard liner/shell materials types. Other material types and/or material thicknesses are available, however using non-standard material types/thicknesses may extend the delivery, always consult the factory for availability.

GRM SERIES PREFIX EXAMPLES

AIR INSULATED MODELS:

GR3A = Model GRA with 3” air space between the liner and shell

GR4A = Model GRA with 4” air space between the liner and shell

INSULATION INSULATED MODELS:

GR3+ = Model GRplus with 3” mineral wool insulation between the liner and shell

GR4+ = Model GRplus with 4” mineral wool insulation between the liner and shell

GR3C = Model GRplus with 3” ceramic insulation between the liner and shell

GR4C = Model GRplus with 4” ceramic insulation between the liner and shell

JOINT ASSEMBLY

According to NFPA 96, all grease ducts are to be liquid tight. The following steps are to be used to ensure this requirement is met.

Use silicone sealant, Van-Packer part number 101087A. **WARNING:** Do not substitute any type of water soluble sealants in the flange area.

STEP 1

Inspect all liner flanges, and draw bands and straighten any mild deformations that may have occurred during shipping.

STEP 2

To ensure sealant adhesion, degrease and remove any dirt and debris from the liner flanges. Use an acetone based cleaner sprayed on a rag.

STEP 3

Apply a 1/4" continuous bead of sealant to one of the liner flanges to be joined.

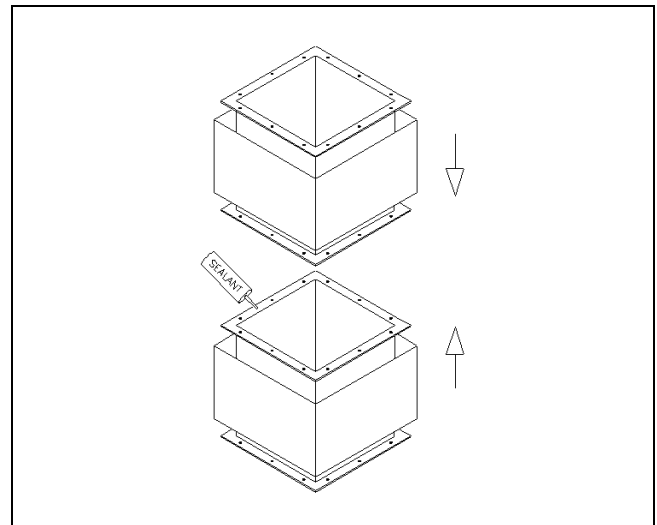

STEP 4

Butt the flanged ends of the sections being joined, being careful not to smear off the sealant.

Install all supplied bolts/nuts finger tight. After all bolt/nuts are installed on a joint snug them up. After everything is snug finish tightening all bolts to an approx. torque of 4 ft-lb, per bolt manufactures recommended bolt torque.

Remove / wipe smooth any excess sealant on the inside of the assembled duct.

Allow sealant to cure 7 days before use. Sealant will not bond to flanges if moisture is introduced into system before sealant has cured.

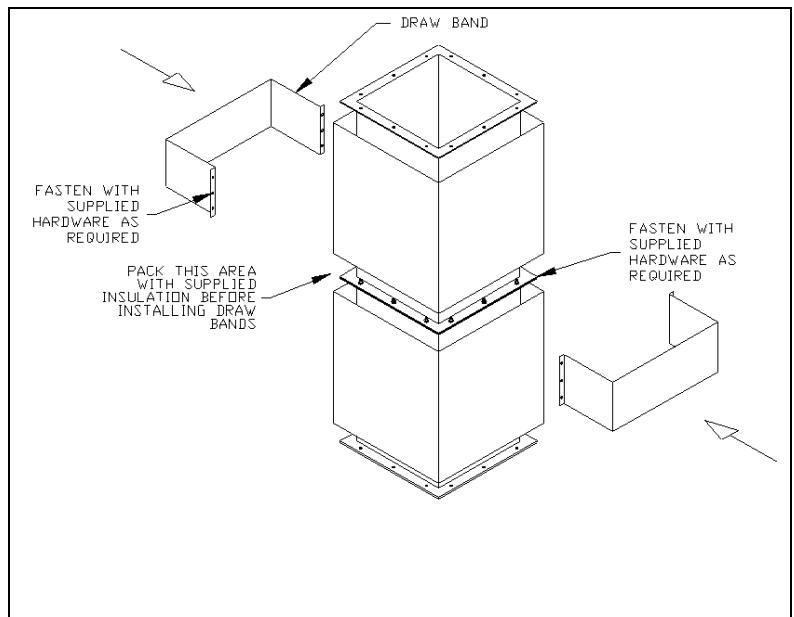

STEP 5

If installing Model GRplus series, install provided insulation strips to ensure all gaps are filled. *(This method applies wherever a joint requires to be wrapped prior to installing a draw band or cover.)*

STEP 6

Complete the grease duct enclosure by placing the draw band around and overlapping the shell edges of the assembled components. With the provided fasteners and appropriate tools draw up the band accordingly. It is recommended that sealant (provided by others) be applied to the draw band edges to prevent moisture from entering between the duct walls on all sections exposed to the atmosphere. As necessary, self tapping screws can also be used to help seal the draw band to the outer shell. (provided by others). Recommended to have a minimum of two screws, per band, in the vertical run.

FLANGE / DRAW BAND FASTENERS

The fasteners provided with the flange are standard ¼"-20 hex bolts and nuts. Draw band fasteners are ¼" – 20 philips pan head screws with square nuts. Fittings come standard with draw band/cover, the fasteners provided for the flange will be plated steel. The provided fasteners for draw band/cover will be plated steel (where the shell is aluminized steel) or stainless steel (where the shell is stainless steel).

INSULATION - PROVIDED ON INSULATED MODEL ONLY (GR+ Series)

Where the finished duct assembly uses a draw band (part **DRW*) a roll or strip of strip insulation is provided. Draw bands are used wherever standard fittings are assembled in series (most fittings are provided with a draw band)

SEALANT USAGE (Approximate)

I.D. inside dimension	JOINTS PER TUBE
06"x06"	20
06"x12"	13
06"x18"	10
06"x24"	8
06"x30"	6
06"x36"	5
12"x12"	10

I.D. inside dimension	JOINTS PER TUBE
12"x18"	8
12"x24"	6
12"x30"	5
12"x36"	5
12"x42"	4
12"x48"	4
18"x18"	6

I.D. inside dimension	JOINTS PER TUBE
18"x24"	5
18"x30"	5
18"x36"	4
18"x42"	4
18"x48"	3
24"x24"	5
24"x30"	4

I.D. inside dimension	JOINTS PER TUBE
24"x36"	4
24"x42"	3
24"x48"	3
30"x30"	4
30"x36"	3
30"x42"	3
30"x48"	3

I.D. inside dimension	JOINTS PER TUBE
36"x36"	3
36"x42"	3
36"x48"	2
42"x42"	2
42"x48"	2
48"x48"	2

INSTALLED WEIGHT PER FOOT (Approximate), Model GRA with 3" & 4" air space

I.D. inside dimension	GR3A	GR4A
06"x06"	10	11
06"x12"	14	15
06"x18"	17	18
06"x24"	20	21
06"x30"	24	25
06"x36"	31	32
12"x12"	17	18
12"x18"	20	21
12"x24"	24	25
12"x30"	27	28
12"x36"	34	36
12"x42"	38	40

I.D. inside dimension	GR3A	GR4A
12"x48"	42	43
18"x18"	24	25
18"x24"	27	28
18"x30"	31	32
18"x36"	38	40
18"x42"	42	43
18"x48"	46	47
24"x24"	31	32
24"x30"	34	35
24"x36"	42	43
24"x42"	46	47
24"x48"	50	51

I.D. inside dimension	GR3A	GR4A
30"x30"	37	38
30"x36"	46	47
30"x42"	50	51
30"x48"	53	55
36"x36"	50	51
36"x42"	54	55
36"x48"	58	59
42"x42"	58	59
42"x48"	61	63
48"x48"	65	66

INSTALLED WEIGHT PER FOOT (Approximate), Model GRplus Series with 3" & 4" mineral wool or ceramic insulation

I.D. inside dimension	GR3+ GR3C	GR4+ GR4C
06"x06"	15	18
06"x12"	20	23
06"x18"	25	29
06"x24"	30	34
06"x30"	35	40
06"x36"	43	49
12"x12"	25	29
12"x18"	30	34
12"x24"	35	40
12"x30"	40	45
12"x36"	48	55
12"x42"	54	61

I.D. inside dimension	GR3+ GR3C	GR4+ GR4C
12"x48"	59	67
18"x18"	35	40
18"x24"	40	45
18"x30"	45	51
18"x36"	54	61
18"x42"	59	67
18"x48"	64	73
24"x24"	45	51
24"x30"	50	56
24"x36"	59	67
24"x42"	64	73
24"x48"	70	79

I.D. inside dimension	GR3+ GR3C	GR4+ GR4C
30"x30"	55	61
30"x36"	64	73
30"x42"	70	79
30"x48"	75	85
36"x36"	70	79
36"x42"	75	85
36"x48"	80	91
42"x42"	80	91
42"x48"	86	96
48"x48"	91	102

SUPPORT LOAD LIMITATIONS

Plate Support Assembly (PLS, see page 12) can hold a maximum of 2,400 pounds.

Flange Support Assembly (FSA, see page 13) can hold a maximum of 3,400 pounds.

Horizontal Angle Supports or Unistrut Supports (see page 14) can hold a maximum of 500 pounds.

Horizontal Hanger Bands (BHB, see page 14) can hold a maximum of 420 pounds.

Wall Brackets 4" thru 32" hold 1300 pounds, 34" thru 48" hold 900 pounds, also see page 13.

Please use charts above for converting pounds into maximum feet.

Please note installed weights above are Based on straight runs, please take into consideration weight per foot may vary for some fittings etc.

DUCT SECTIONS & FITTINGS

Van-Packer makes a wide range of prefabricated adapters, fittings, elbows, wye's, tee's, transitions, increasers, terminations, etc. Refer to the GRM series brochure for additional information on part number designations and the wide range of parts and fittings we offer to complete a system from start to finish. In general all sections are assembled with a bolt flange connection; however, below are a few examples of parts that may require special attention.

FAN/HOOD ADAPTER ASSEMBLY – PART FAA

The Fan Adapter Assembly is intended to be used with a “traditional” roof curb (provided by others) and connection to a hood or an exhaust fan. The FAA is comprised of a fan adapter plate (specify plate size at time of purchase) with a factory installed starter section that assembles to a standard fitting. Field connect the plate to the hood, curb or fan by (drilling / fasteners & sealant by others as required). Refer to the hood, fan unit or the roof curb manufacturer's installation requirements.

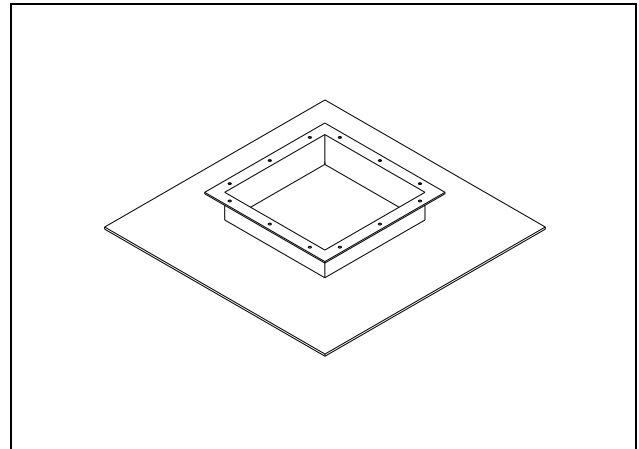

FITTINGS & STRAIGHT SECTIONS

Fittings and Straight Sections are fixed degrees, lengths, etc., joined together to complete desired grease duct runs. These sections may also be equipped (must be factory installed) with nipples or couplings to accommodate test probes, fire suppression nozzles, sprinkler heads, drainage, etc. Refer to the GRM series brochure for designation of part lengths and options for adding pipe nipples / couplings.

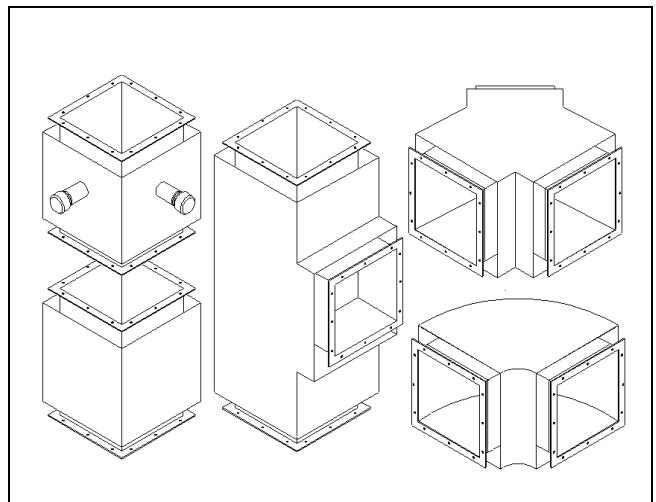

ACCESS PANEL SECTION – PART APS

This part is intended to be used for clean out access. When the access panel section is installed in a horizontal position, it must be orientated in accordance with applicable codes. Please refer to the GRM series brochure for additional information and part number designation.

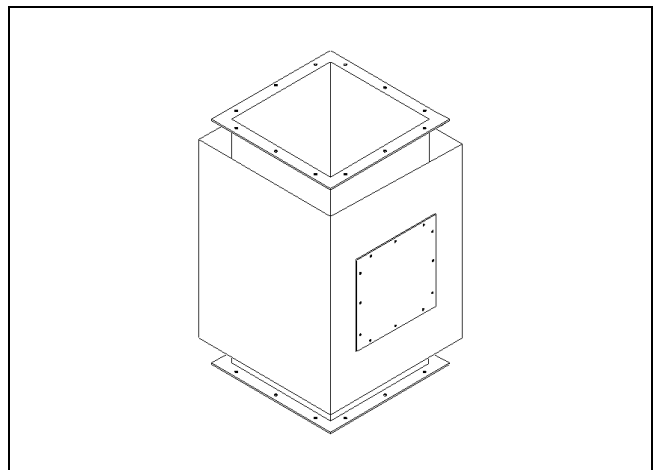

DUCT SECTIONS & FITTINGS CONTINUED

OPEN TOP CLOSURE – PART OTC

The Open Top Closure covers the space between the liner and shell. First, position the OTC around the liner. Next, butt the OTC up against the flange of the liner and using the provided fasteners draw up the OTC. Last, apply a bead of sealant at the upper edge of the OTC, where the raw edge of steel contact the duct liner, to form a weather tight seal.

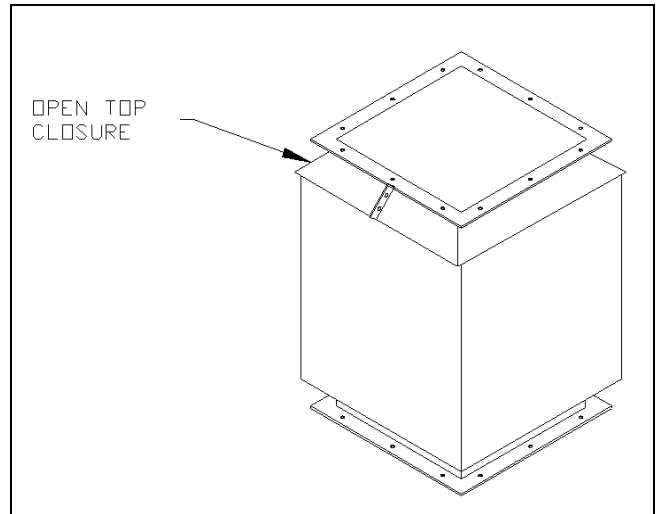

RAIN CAP – PARTS RCS

Rain Caps connect to the liner flange per the joint assembly instructions. The space between the liner and shell is then covered using a rain skirt. The rain skirt is installed by positioning the rain skirt around the liner just below the previously installed flange. Next, using the provided fasteners draw up the rain skirt (the rain skirt should be overlapping and in contact with the top of the shell). Last, apply a bead of sealant at the upper edge of the rain skirt, where the raw edge of steel contact the duct liner, to form a weather tight seal.

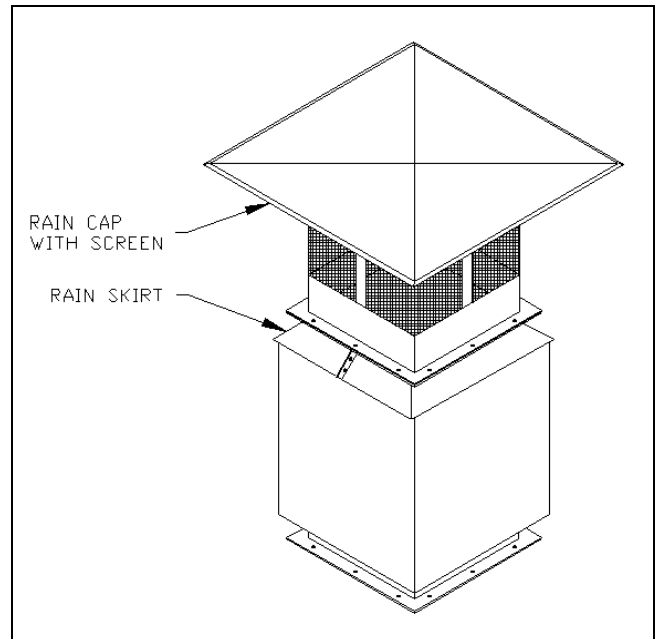

SUPPORTS & GUIDES

NOTES: The structural engineer for the project should select support member channels, beams, rods, wires/cables, etc. and joining methods in accordance with *Good Engineering Practices* to suite each specific application. Rods, wires/cables should only be used for hangers, NOT supports. Van-Packer accepts no responsibility for the design and/or modification of buildings or structures to accept the given load. All support framing, anchoring methods, etc. are by others.

STRUCTURAL SUPPORTS

PLATE SUPPORT ASSEMBLY – PART PLS

Plate Support Assemblies are used for vertical & horizontal (breaching anchor) structural support applications. The PLS is to be used with structural support members, which are designed by the building structural engineer not Van-Packer. Refer to page 7 for structural support limitations.

STEP 1

Carefully follow the joint assembly instructions on page 6, steps 1 thru 6, with the exception of adding the plate support in-between the flanges. Refer to chart for load limitations. Do not install near combustible material.

Installation Tip: It will be easier to assemble the two sections with the plate support on the floor. Then raise up into desired location to be attached to the structural support.

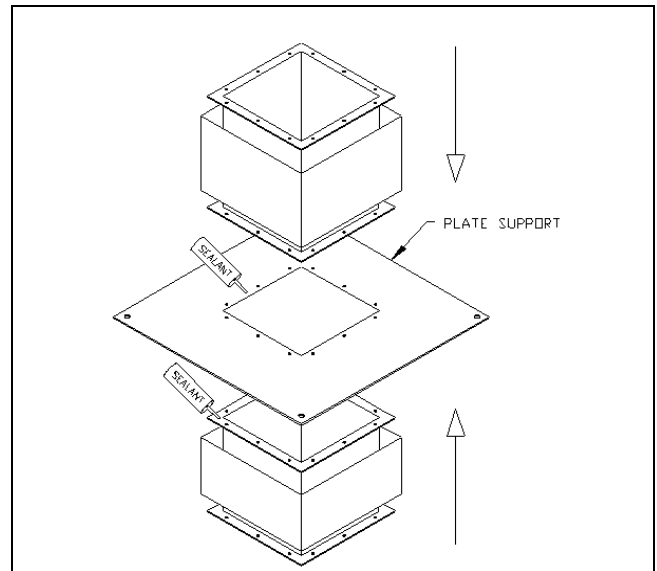

Note:

Support all four sides of the support plate. Design support member and fasteners in accordance with good engineering practices to suit each specific application. Van-Packer assumes no responsibility for the design and/or modification of buildings or structures to accept the given loads.

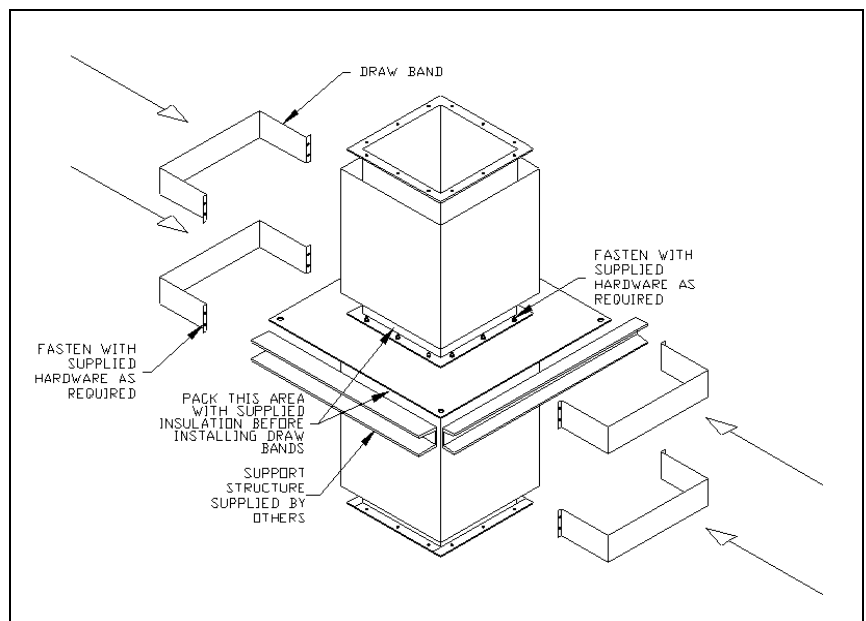

SUPPORTS & GUIDES

STRUCTURAL SUPPORTS - CONTINUED

FLANGE SUPPORT ASSEMBLY – PART FSA

A Flange Support Assembly is a prefabricated section with a plate support installed at the factory for structural support applications. The FSA is to be used with structural support members, which are designed by the building structural engineer not Van-Packer. Refer to page 9 for structural support limitations.

Note:

Support all four sides of the support plate. Design support member and fasteners in accordance with good engineering practice to suit each specific application. Van-Packer assumes no responsibility for the design and/or modification of buildings or structures to accept the given loads. Refer to chart for load limitations. Do not install near combustible material.

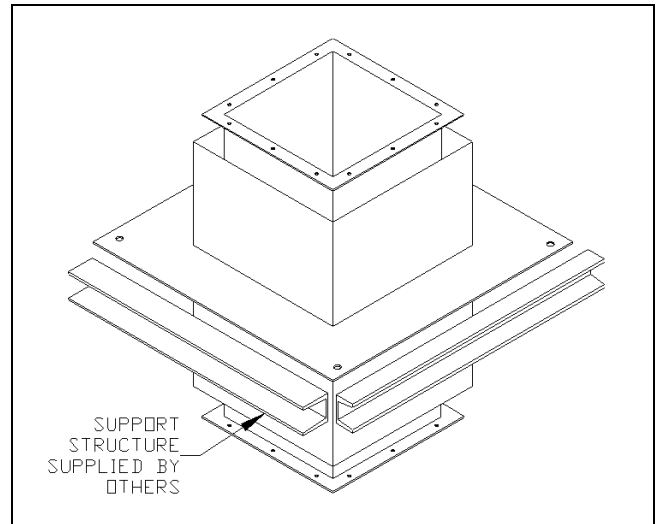

WALL BRACKETS – PART WBR

Wall Brackets are used in conjunction with our vertical and horizontal structural and lateral supports. The WBR, in conjunction with anchor bolts or in some instances additional field fabricated support members from the wall brackets to the building or structure, is intended to provide a rigid (static) support location. This rigid support location is intended to withstand the weight of duct components, forces from thermal expansion & exhaust velocities, etc. The WBR is comprised of (2) wall brackets, (left and right) Refer to chart on page 9 for bracket support limitations.

STEP 1

Anchor the wall brackets to the wall or additional field fabricated support members accordingly. Design support member and fasteners in accordance with good engineering practices to suit each specific application. Van-Packer assumes no responsibility for the design and/or modification of buildings or structures to accept the given loads. Refer to chart for load limitations. Do not install near combustible material.

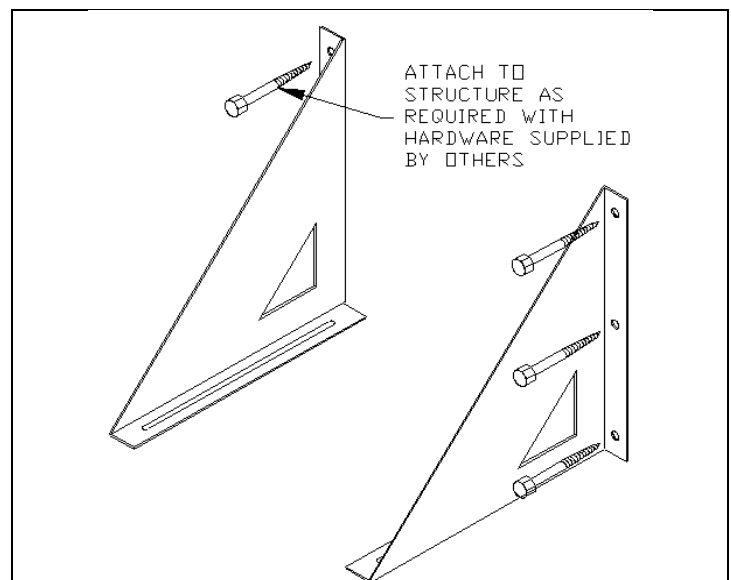

SUPPORTS & GUIDES

HORIZONTAL SUPPORTS

We have a few horizontal support options. Refer to page 9 for options and support weight limitations. Use supports in conjunction with rods or other field fabricated support members attached to the building or structure. Horizontal supports hold the weight of horizontal assembly and also maintain alignment. Position the support away from draw bands & covers. Please note max. spacing of 12 foot making sure to stay within the weight limitation on page 9.

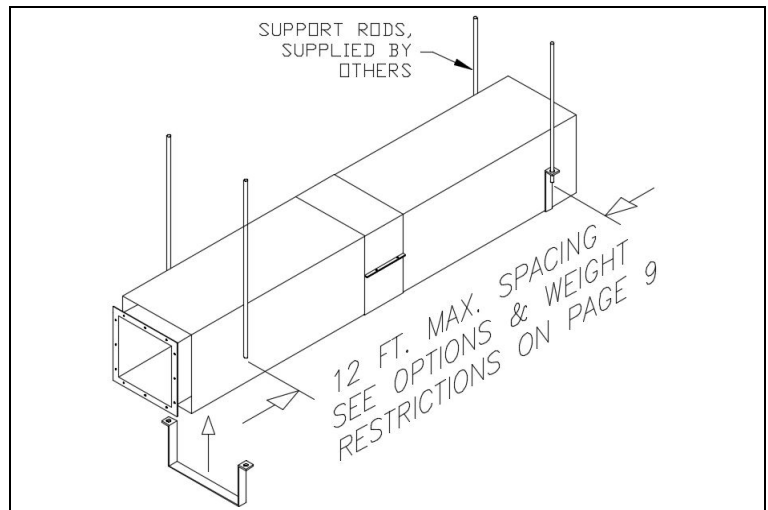

LATERAL BRACES

FULL ANGLE SUPPORT – PART FAS

Full Angle Supports, in conjunction with field fabricated support members from the FAS attached to the building or structure, are intended to laterally brace the vertical assembled duct lengths from wind loads and to also maintain alignment as the duct expands and contracts. The FAS is comprised of (2) halves and when bolted together has a slight clearance fit to the duct. Position the FAS away from draw bands & covers as to allow for the unrestricted expansion and contraction of the duct system. FAS's cannot be installed over draw bands.

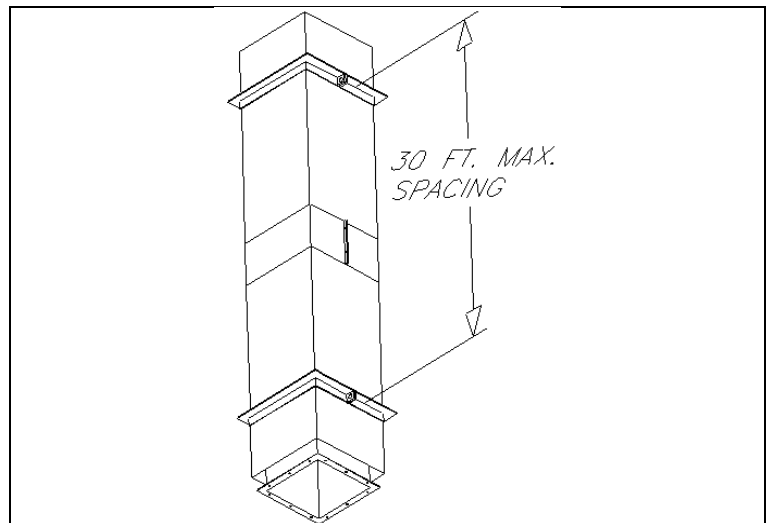

GUY ATTACHMENT PLATE – PART GAP

Guy Attachment Plate, in conjunction with wires, tensioners, anchors, and other miscellaneous hardware from the GAP attached to the building structure, are intended to laterally brace the vertical assembled duct lengths from wind loads and to also maintain alignment as the duct expands and contracts.

STEP 1

Carefully follow the joint assembly instructions on page 6, steps 1 thru 6, with the exception of adding the Guy Attachment Plate in-between the flanges.

Note:

Install the necessary wires, tensioners, anchors, miscellaneous hardware, etc. (by others) A minimum of (4) wires/cables equally spaced is recommended.

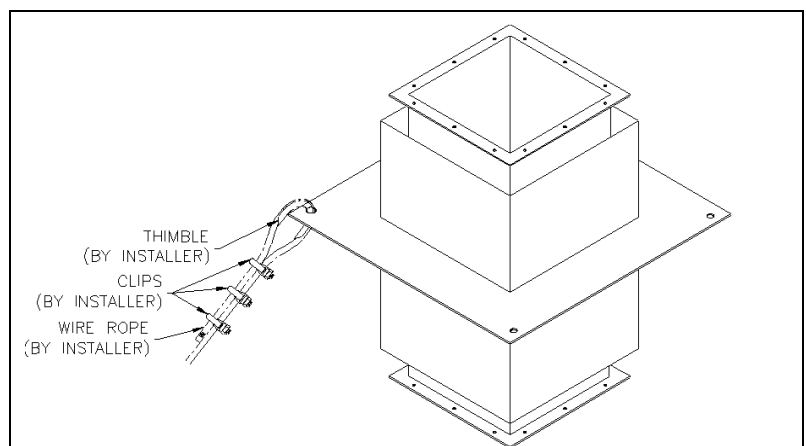

PENETRATION FLOORS/CEILINGS & WALLS – WHEN FIRE RATING IS NOT REQUIRED

FINISHING PLATE - PART FPL

The Finishing Plate can be used when the duct passes through a floor/ceiling or wall where a fire rating is not required. The minimum rough opening (square or round opening allowed) must be enough to allow the duct to pass through, approximately duct O.D. +2". The maximum rough opening is duct O.D. +8" (Max. opening size when duct is centered through the opening). The FPL includes (1) plate assembly. Please note two plate assemblies shown below in the picture.

Cut the rough opening accordingly and assemble the duct through. Position the plate halves (allow slight clearance to the duct O.D. to accommodate any expansion as needed), Anchor the plates with appropriate fasteners (by others) at hole locations.

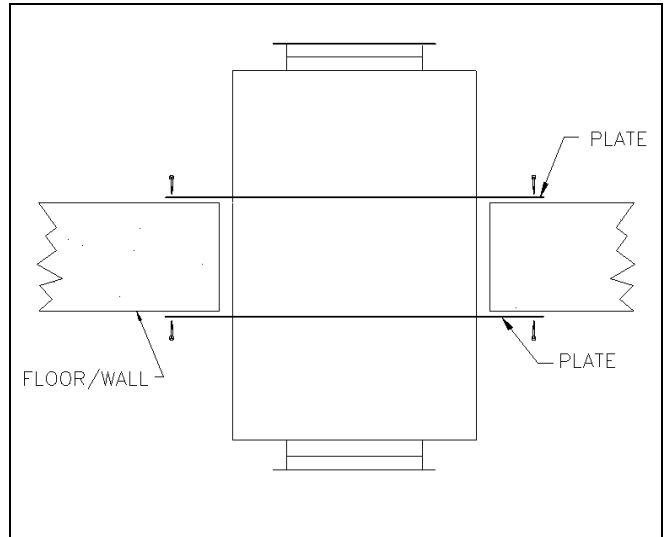

ROOF PENETRATION

FLASHING & COUNTER FLASHING - PARTS FLS & CFL

The Flashing and Counter Flashing can be used when the duct passes through a roof or curb where a roof penetration thimble is not required. Pitched Flashings are available. The minimum rough opening (square or rectangular opening allowed) must be enough to allow the duct to pass through, approximately duct O.D. +2". The maximum recommended rough opening is duct O.D. +8" (reflects flat roof only and duct centered through opening).

STEP 1

Cut the rough roof opening. Center the Flashing around the opening and with appropriate fasteners attach it to the roof. Roofing materials to complete a weather tight seal should be installed over the square base of the flashing.

STEP 2

Assemble the duct through the Flashing accordingly. Next, install the Counter Flashing by positioning it around the duct and against the screen at the top of the Flashing. Then, with the provided fasteners draw up the Counter Flashing. Last, apply a bead of sealant at the upper seam of the Counter Flashing and duct. *Note: Roofing materials must not fill the entire space between the roof and the bottom of the counter flashing.*

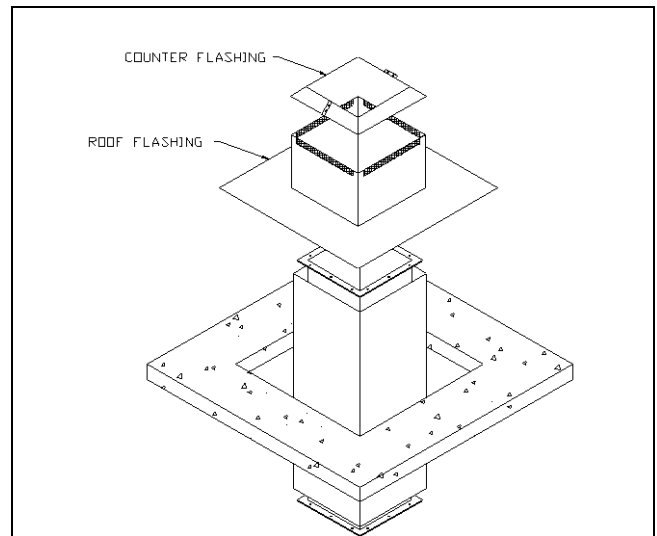

SYSTEM INSTALLATION EXAMPLE

Below shows an installation example. This example is intended to reflect general requirements for support locations, with respect to fittings and to also show standard support locations for an installation in accordance with its design listing. This example may not reflect all necessary supports, drains, etc. which may be required to meet applicable codes and to help ensure a well functioning duct system (refer to applicable codes as required).

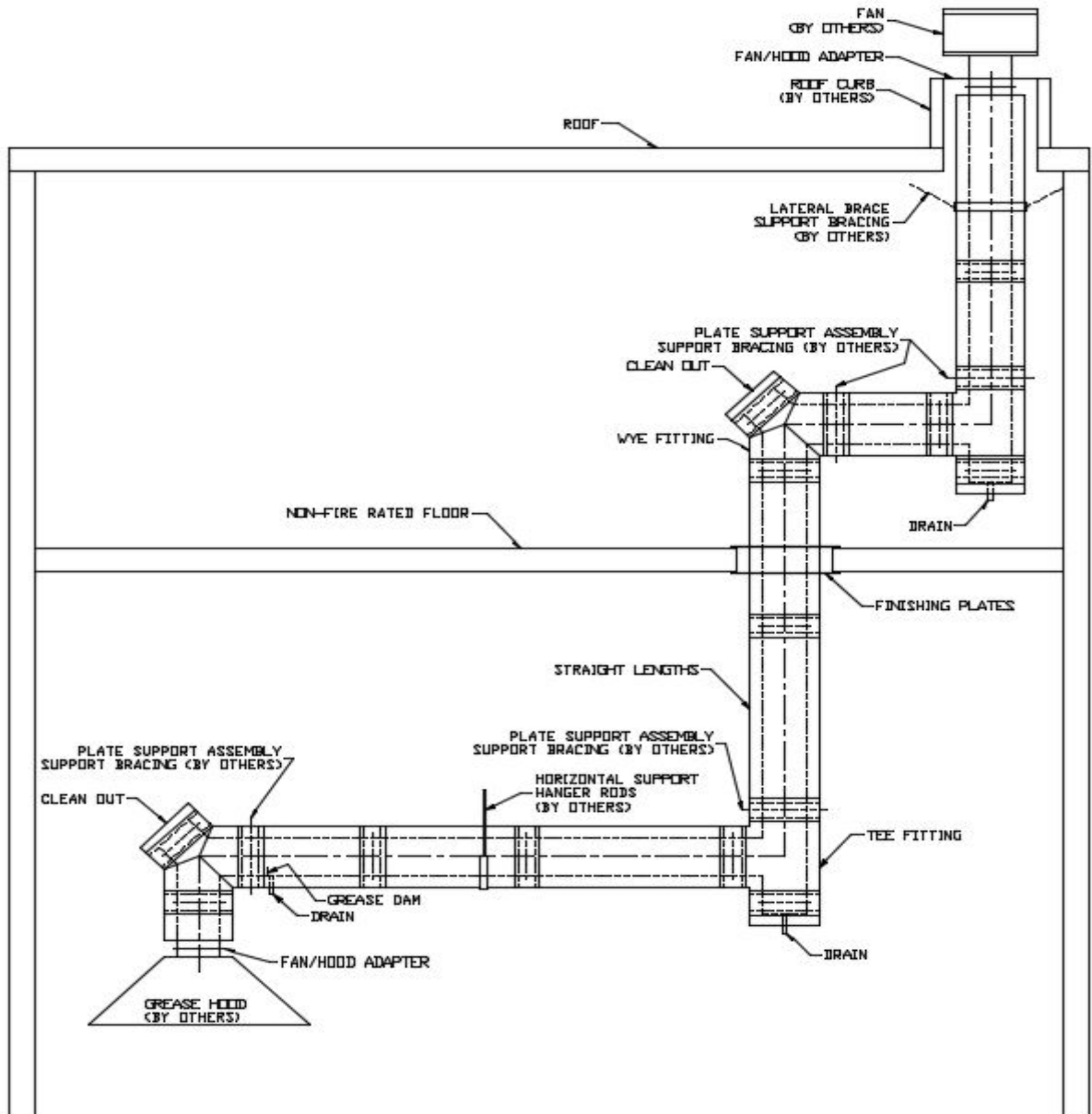

Van-Packer Company
Sales, Service and Manufacturing
302 Mill Street, PO Box 307
Buda, Illinois 61314-0302
Phone 1-888-VPSTACK (1-888-877-8225) or 1-309-895-2311
Fax 1-309-895-3891
Tech Email vptech@vpstack.com
Web Site www.vpstack.com

GRM Installation Guidelines 08/10/21