

# MODEL GA

(Double Wall Grease Duct Systems, 1"-4" Air Space)

# MODEL G<sub>Plus</sub>

(Double Wall Grease Duct Systems, 1"-4" Mineral Wool Insulation Space, G<sub>+</sub>) or  
(1"-4" Ceramic Fiber Insulation Space, G<sub>C</sub>)

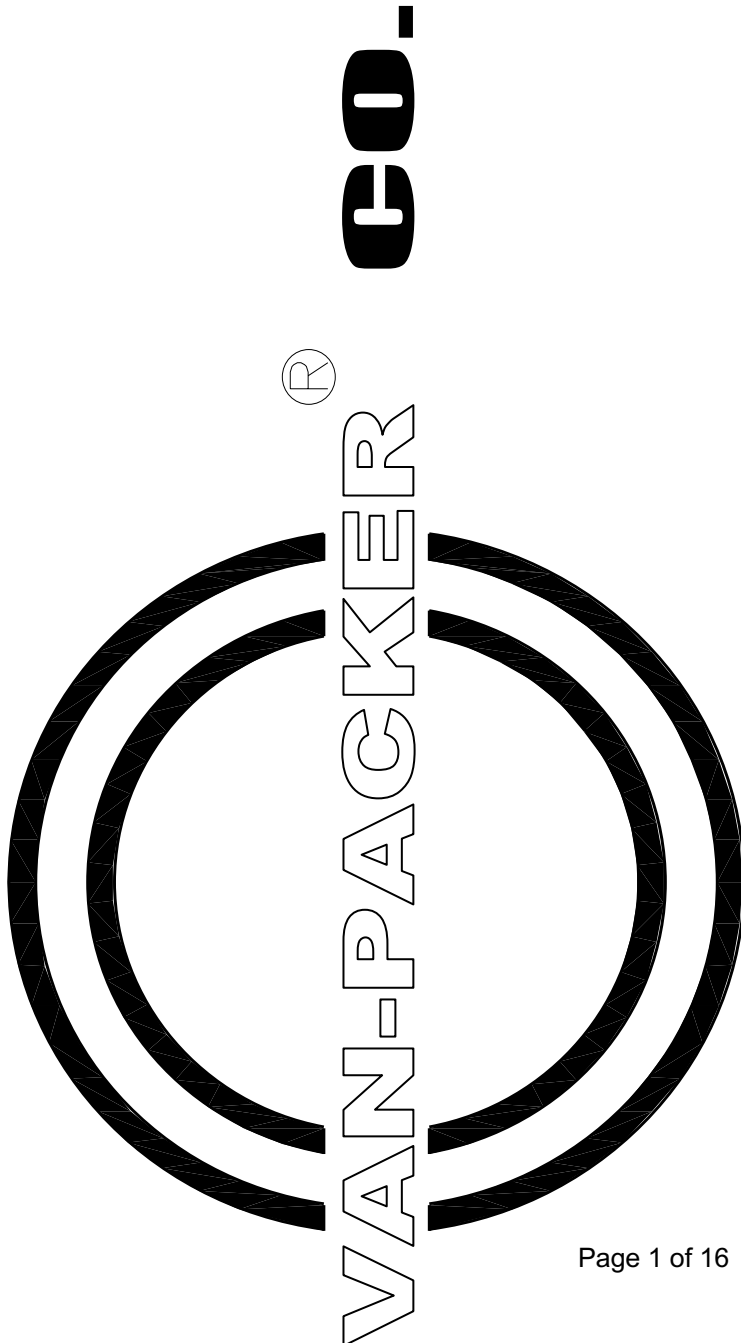

**Installation Guidelines**  
Tested to: UL 1978 / ULC S662



## TABLE OF CONTENTS

<b>LISTING &amp; CODE COMPLIANCE</b> . . . . .	<b>3</b>
<b>TESTING, CLASSIFICATION, &amp; APPLICATIONS.</b> . . . . .	<b>3</b>
<b>GENERAL INFORMATION</b> . . . . .	<b>3-5</b>
CLEARANCES & ADDITIONAL ENCLOSURES . . . . .	3
CODES & AUTHORITIES. . . . .	4
INSTALLATION CONSIDERATIONS . . . . .	4
MIXING SYSTEMS & PARTS. . . . .	4
DUCT SLOPE. . . . .	4-5
CLEANOUTS, DRAINS & GREASE TRAPS . . . . .	5
APPLICATIONS . . . . .	5
<b>RECEIVING INSPECTION</b> . . . . .	<b>5</b>
TYPICAL COMPONENT LOCATIONS . . . . .	5
FREIGHT DAMAGE. . . . .	5
<b>PART IDENTIFICATION &amp; MATERIAL CODES</b> . . . . .	<b>6</b>
<b>JOINT ASSEMBLY</b> . . . . .	<b>7</b>
SEALANT USAGE. . . . .	8
INSTALLED WEIGHT CHART. . . . .	8-9
HEIGHT LIMITATIONS. . . . .	8-9
<b>SECTIONS &amp; FITTINGS</b> . . . . .	<b>10-12</b>
ADAPTERS . . . . .	10
FITTINGS & STRAIGHT SECTIONS . . . . .	10
ACCESS PANEL & GREASE DRAINS . . . . .	11
TERMINATIONS . . . . .	11
ADJUSTABLE AND VARIABLE LENGTH SECTIONS . . . . .	12
COVER PLATE . . . . .	12
<b>SUPPORTS &amp; GUIDES.</b> . . . . .	<b>13-15</b>
STRUCTURAL SUPPORTS. . . . .	13-14
HORIZONTAL SUPPORT HANGER . . . . .	14
LATERAL BRACES & GUIDES. . . . .	15
<b>PENETRATIONS.</b> . . . . .	<b>16</b>
ROOF PENETRATIONS . . . . .	16
<b>SYSTEM INSTALLATION EXAMPLE.</b> . . . . .	<b>17</b>

### WARNING

Major causes of grease duct fires are failure to maintain required clearance to combustibles and failure to clean and remove grease build-up from the duct system. It is important to read and understand these instructions fully before installing this grease duct system. Failure to comply with these instructions will result in a hazardous installation and will void the warranty.

### STANDARD WARRANTY

When this system, provided by the Van-Packer Company, is installed per these instructions, we warrant the parts to be free from defects in material and workmanship for a period of 12 months from the date of shipment. For warranty questions please contact the technical service department for further details and stipulations.

## LISTING & CODE COMPLIANCE

Van-Packer's Model GA or Gplus grease duct is listed by UL as "2 to 17 inch clearance to combustibles (see chart below) grease duct assembly" and as "Grease Ducts for Restaurant Cooking Appliances" when installed in accordance with these instructions and the National Fire Protection Association's standard NFPA 96 "Standard for Ventilation Control and Fire Protection of Commercial Cooking Operations," International Mechanical Code, Uniform Mechanical Code, or other local codes.

## TESTING, CLASSIFICATION, & APPLICATIONS

Model GA or Gplus has been tested in accordance with the procedures and methods set forth by UL 1978/ULC S662 (Standard for Grease Ducts/Standard for Factory-Built Grease Ducts).

Model GA or Gplus Grease Ducts are rated for:

1. Continuous operation at 2 to 17 inch clearance to combustibles (see chart below).
2. Continuous operation at zero inch clearance to non-combustibles.
3. Removal of smoke and grease laden vapors from commercial, industrial, etc. cooking applications.
4. Continuous operating temperatures are 500° F (260° C) or less and for intermittent temperatures not exceeding 2000° F (1093° C).
5. Venting negative, neutral, and positive pressure applications.
6. Positive pressures up to 60 inches water column.

Model GA or Gplus grease ducts are intended to be part of a complete grease duct system which connects the hood or grease extractor with the outdoors by means of an exhaustor or blower system.

## CLEARANCE TO COMBUSTIBLES

Model GA 1", 2", 3" or 4" Air Space	
Duct I.D.	Clearance
06"	7" (178 mm)
07"-10"	8" (203 mm)
12"	9" (229 mm)
14"-18"	10" (254 mm)
20"-22"	11" (279 mm)
24"-28"	12" (305 mm)
30"-32"	13" (330 mm)
34"-36"	14" (356 mm)
38"-40"	15" (381 mm)
42"-44"	16" (406 mm)
46"-48"	17" (432 mm)

Model Gplus & Gplus2 1" or 2" Insulation Space	
Duct I.D.	Clearance
06"	4" (102 mm)
07"-12"	5" (127 mm)
14"-18"	6" (152 mm)
20"-24"	7" (178 mm)
26"-28"	8" (203 mm)
30"-34"	9" (229 mm)
36"-40"	10" (254 mm)
42"-48"	11" (279 mm)

Model Gplus3 & Gplus4 3" or 4" Insulation Space	
Duct I.D.	Clearance
6"-12"	2" (51 mm)
14"-18"	3" (76 mm)
20"	4" (102 mm)
22"-26"	5" (127 mm)
28"-32"	6" (152 mm)
34"-36"	7" (178 mm)
38"-40"	8" (203 mm)
42"-48"	9" (229 mm)

## GENERAL INFORMATION

**WARNING:** Code compliant clearances must be followed where any components are in direct contact with the liner. Examples of this would be support assemblies, drain pipes, or any other similar items. Do not install these items near combustible material.

When installed in accordance with these instructions and codes, Model GA or Gplus grease ducts are equivalent to field fabricated grease duct systems. Do not apply wraps or enclosure materials in direct contact with Van-Packer's products in a manner that adds additional weight to our duct. Model GA or Gplus has not been tested, listed, designed, etc. to carry additional weight from such materials.

## HOURLY RATED ENCLOSURE

Where a building is more than one story in height or for a one story building where the roof-ceiling assembly requires a fire resistance rating, the duct must be enclosed by an hourly rated enclosure. If the building is less than four stories in height, the enclosure must have a fire resistance of not less than one hour. For buildings of four stories or more, the enclosure must have a resistance rating of not less than two hours.

## GENERAL INFORMATION - CONTINUED

### CODES & AUTHORITIES

Installation must be made in accordance with local and national code requirements. Follow these instructions carefully and contact local building and fire officials about restrictions and installation inspection in your area. Refer to NFPA 96 (*Standard for Ventilation Control and Fire Protection of Commercial Cooking Operations*) and additional NFPA standards as required.

### INSTALLATION CONSIDERATIONS

Follow Van-Packer's written installation instructions carefully. Each part of the grease duct system must be installed correctly. Improper or lack of installation of required parts may result in the improper function of the grease duct system. Always contact the technical service department with any questions.

The grease duct layout should be carefully planned to allow adequate space for assembly, installation of supports, connection of support framing, access for cleanouts, accommodate standard fitting dimensions, rough openings for penetrations, etc. Do not assume all equipment producing smoke or grease laden vapors within a facility can be exhausted with a single grease duct system. Consult a grease duct design professional as required.

One prime coat and finish coat of appropriate paint is recommended on any non-stainless steel accessories that are in areas subject to cleaning or exposed to the weather. Stainless steel accessories are available upon special request.

### MIXING SYSTEMS & PARTS

Do not connect a grease duct system with any other building ventilation or exhaust system. Do not connect parts from other grease duct manufacturers with Model GA or Gplus components without the expressed consent of Van-Packer.

Components from other Van-Packer product lines, (for example Model GZ, GRZ, GS or GRS), may be mixed with Model GA or Gplus components to complete a grease duct system as long as: clearances, limitations, codes, etc. are followed. Contact Van-Packer for more information concerning product lines which are listed for use as grease ducts.

Van-Packer grease duct components are designed to complete the entire system. However, we realize conditions occur where systems must be mixed. In these cases, in accordance with *good construction methods and codes* it is permissible to transition to/from a code compliant grease duct system (by others) to/from Van-Packer grease duct components. Connection must be an approved joint assembly method as described within installation instructions, and/or applicable codes. Transition (by others) cannot connect in a manner that adds additional weight/stress to our duct. Van-Packer's products have not been tested, listed, designed, etc. to carry additional weight from such transitions. **WARNING:** Listings / warranties may be affected when transitioning to / from grease ducts by others; consult Van-Packer technical service department for additional information.

### DUCT SLOPE

Model GA or Gplus grease ducts must be installed accordingly to comply with the requirements as described in order to maintain a listed installation. UL states that these grease ducts must comply with requirements as set forth by UL 1978 (*Standard for Grease Ducts*), NFPA 96 (*Standard for Ventilation Control and Fire Protection of Commercial Cooking Operations*), and the International Mechanical Code. Model GA or Gplus grease ducts should be installed at a slope not less than 1/16 unit vertical in 12 units horizontal toward the hood or toward a grease reservoir. Where horizontal ducts exceed 75 feet in length, the slope shall be not less than 1/4 unit vertical in 12 units horizontal. Most Model GA or Gplus components will permit a small amount of slope as the system is being installed. However, some installations may require elbow / transition type pieces to allow for proper orientation of fittings at the vertical risers prior to and after long horizontal runs. It is also acceptable for ducts to have staggered sloped (e.g., uphill to a peak point, then downhill to a valley point), the distance between a valley point and peak point must follow the limitations above and every valley must allow for grease drainage (i.e., a hood or reservoir). Contact Van-Packer for additional information.

## **GENERAL INFORMATION - CONTINUED**

### **CLEANOUTS, DRAINS, & GREASE TRAPS**

Many Model GA or Gplus sections, accessories, and combinations can be used for cleanout and inspection access of the grease duct system. Access panel sections, 90° tee sections with end caps, and many other combinations of components can serve as cleanout doors or openings as described by NFPA 96. Grease ducts must be provided with adequate cleanout doors or openings to allow for the inspection and cleaning of the entire grease duct system. Refer to NFPA 96 for specific requirements.

Cleanout, drain, and grease trap requirements may change when grease duct systems are equipped with automatic cleaning and / or some types of fire suppression equipment. Refer to NFPA 96 and additional codes / authorities having jurisdiction for specific duct system requirements.

### **WASH DOWN & FIRE SUPPRESSION**

Automatic hot water / detergent wash down and fire suppression systems can be integrated into a Model GA or Gplus grease duct system by using various components which are readily available (or by request sections can be factory fit) with threaded pipe nipples, couplings, etc.

Van-Packer does not provide, design, specify, etc. wash down and fire suppression equipment or systems. Refer to NFPA 96 and additional codes / authorities having jurisdiction for specific fire suppression system requirements. Some of the various types of fire extinguishing equipment / systems are: Carbon Dioxide (NFPA 12), Sprinkler (NFPA 13), Foam-Water (NFPA 16), and Dry Chemical (NFPA 17).

### **APPLICATIONS**

Model GA or Gplus grease duct is suitable for interior or exterior installations. Suitable for the removal of smoke and grease laden vapors from commercial, industrial, institutional, and similar cooking applications. Model GA or Gplus duct systems have various components which are readily available for your venting needs. Always contact Van-Packer for additional uses and information, refer to NFPA 96 and additional codes / authorities having jurisdiction for specific grease duct system requirements.

### **RECEIVING INSPECTION**

Compare the packing list items and quantities with the contents of the containers to ensure completeness of the shipment. If the shipment is missing components, please contact Van-Packer's order entry department at 888-877-8225.

### **TYPICAL COMPONENT LOCATIONS**

Straight sections, fittings, etc. will be positioned and stacked accordingly to fill the shipping container. Sections of smaller dimensions may be slipped into sections of larger dimensions. Bags of fasteners, sealant, etc. may also be located inside the liner of the various pieces.

### **FREIGHT DAMAGE**

Inspect each box as it is unloaded from the carrier for damage which may have occurred during transit. Should there be any damaged components, the delivery receipt must be signed damaged in order for Van-Packer to file a claim with the carrier. If the delivery receipt is signed damaged, contact Van-Packer immediately. If there are damaged parts and the delivery receipt is not signed damaged, Van-Packer or the carrier will not be liable, and damaged parts will be replaced at the customer's expense. Do not return any parts to the factory without prior authorization from Van-Packer Company.

## PART IDENTIFICATION & MATERIAL CODES

Model GA or Gplus part numbers will start with the letter “G” prefix, followed by the air or insulation type and thickness (if applicable) followed by the duct diameter (I.D.), then the part description code, next a special qualifier code (if applicable) and last the liner/shell material designation. Part description codes are generally three characters and are either alpha or alpha numeric. Qualifier codes are most often used to designate section lengths, tee projection dimensions, and the large I.D. end of increasers. The following are a couple examples of part numbers with their associated description and part number breakdown.

### G1A12STR30AL

Refers to a Model GA, with 1” air space, 12” I.D., 30” long straight section constructed with a 304 S.S. liner and an aluminized steel shell.

**G1A** = Model GA, with 1” air space  
**12** = Section I.D.  
**STR** = Part Code, Straight Section  
**30** = Section length, 30” long  
**A** = Liner Material Code, 304 S.S.  
**L** = Shell Material Code, ALZD Steel

### G2A12BTT08BA

Refers to a Model GA, with 2” air space, 12” I.D. 90 degree boot tee section with an 08” I.D. projection constructed with a 316 S.S. liner and 304 S.S. shell.

**G2A** = Model GA, with 2” air space  
**12** = Tee Body, 12” I.D.  
**BTT** = Part Code, 90 Degree Tee Section  
**08** = Tee Projection, 08” I.D.  
**B** = Liner Material Code, 316 S.S.  
**A** = Shell Material Code, 304 S.S.

### G2+1290T08BA

Refers to a Model Gplus, with 2” Mineral Wool insulation, 12” I.D. 90 degree centered tee section with an 08” I.D. projection constructed with a 316 S.S. liner and 304 S.S. shell.

**G2+** = Model Gplus, with 2” Mineral Wool insulation  
**12** = Tee Body, 12” I.D.  
**90T** = Part Code, 90 Degree Tee Section  
**08** = Tee Projection, 08” I.D.  
**B** = Liner Material Code, 316 S.S.  
**A** = Shell Material Code, 304 S.S.

### G3C1245EAC

Refers to a Model Gplus, with 3” Ceramic Fiber insulation, 12” I.D. 45 degree elbow constructed with a 304 S.S. liner and 430 S.S. shell.

**G3C** = Model Gplus, with 3” Ceramic Fiber insulation  
**12** = Section I.D.  
**45E** = Part Code, 45 degree Elbow  
**A** = Liner Material Code, 304 S.S.  
**C** = Shell Material Code, 430 S.S.

### LINER MATERIAL CODES

**A** = 304 S.S.  
**B** = 316 S.S.

### SHELL MATERIAL CODES

**A** = 304 S.S.  
**B** = 316 S.S.  
**C** = 430 S.S.  
**L** = Aluminized Steel

### PREFIX EXAMPLES

#### AIR INSULATED MODELS:

**G1A** = Model GA with 1” air space in between the liner and shell  
**G2A** = Model GA with 2” air space between the liner and shell  
**G3A** = Model GA with 3” air space between the liner and shell  
**G4A** = Model GA with 4” air space between the liner and shell

#### INSULATION INSULATED MODELS:

**G1+** = Model Gplus with 1” mineral wool insulation between the liner and shell  
**G2+** = Model Gplus with 2” mineral wool insulation between the liner and shell  
**G3+** = Model Gplus with 3” mineral wool insulation between the liner and shell  
**G4+** = Model Gplus with 4” mineral wool insulation between the liner and shell

**G1C** = Model Gplus with 1” ceramic fiber insulation between the liner and shell  
**G2C** = Model Gplus with 2” ceramic fiber insulation between the liner and shell  
**G3C** = Model Gplus with 3” ceramic fiber insulation between the liner and shell  
**G4C** = Model Gplus with 4” ceramic fiber insulation between the liner and shell

## JOINT ASSEMBLY

The following steps are to be used to ensure this system has liquid tight joints.

Use high temperature silicone sealant, Van-Packer part number 101087A. **Warning:** allow sealant to cure 72 hours before use. Sealant will not bond to flanges if moisture is introduced into system before sealant has cured.

### STEP 1

Inspect all liner flanges and straighten any mild deformations that may have occurred during shipping.

### STEP 2

To ensure sealant adhesion, degrease and remove any dirt and debris from the liner flanges. Use an acetone based cleaner applied to a rag.

### STEP 3

Apply a continuous bead of sealant (1/8" to 1/4") to one or both of the liner flanges to be joined.

### STEP 4

Butt the flanged ends of the sections being joined, being careful not to smear off the sealant. Re-apply if this happens.

### STEP 5

Apply a bead of sealant into the groove of the vee band.

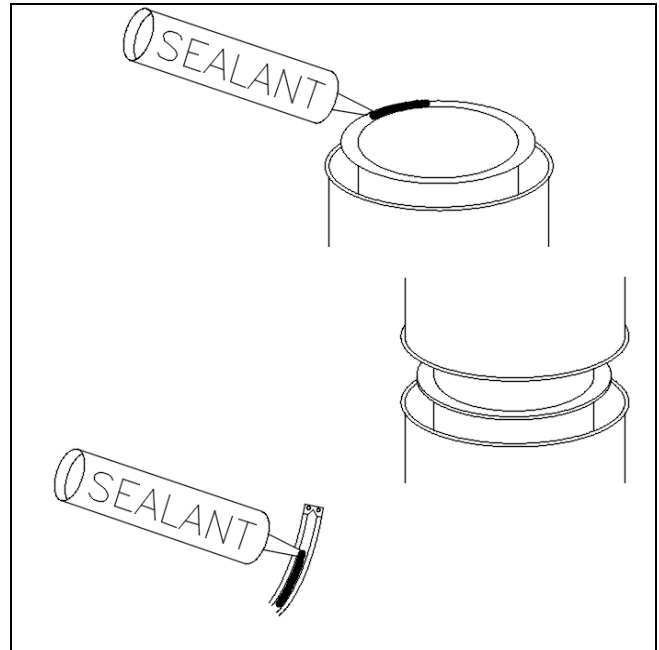

### STEP 6

Install the vee band making sure the vee band overlap tabs slide under the mating end and tighten up. Overlap tabs should be located on the sides of the horizontal duct. It is **necessary** to lightly tap the vee band while tightening to ensure a snug fit.

Wipe smooth any excess sealant on the inside of the assembled duct to prevent sealant dams.

### STEP 7

If installing Model Gplus series, install insulation strips to ensure all gaps are filled.

### STEP 8

Secure the outer shell with the draw band. It is recommended that silicone sealant be applied around the top of the draw band to prevent moisture from entering between the duct walls. This should be done on all components exposed to the atmosphere.

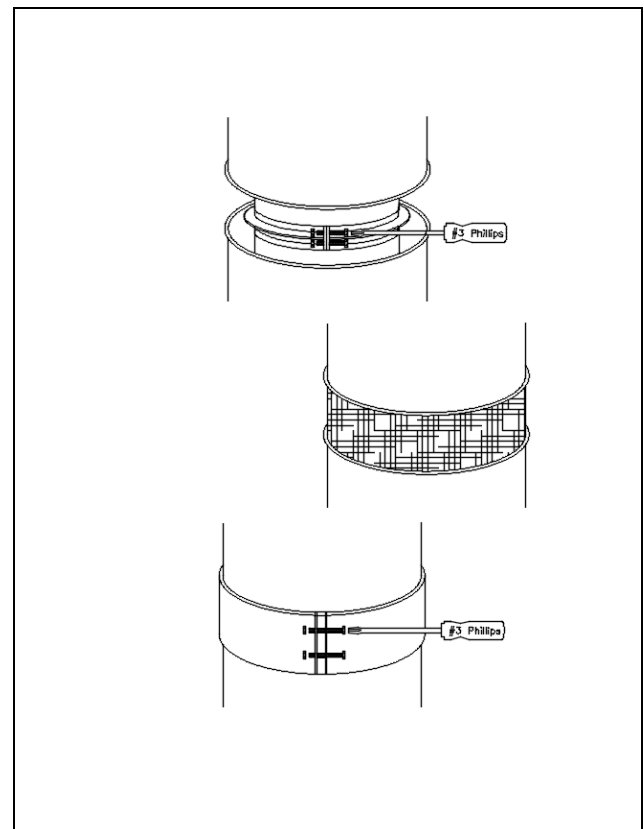

**Failure to follow our instructions could lead to leaking joints.**

**APPROXIMATE SEALANT USAGE**

Section I.D.	6"	7"	8"	9"	10"	12"	14-16"	18"-20"	22"-30"	32"-38"	40"-48"
Joints per Tube	12	10	9	8	7	6	5	4	3	2	1

**APPROXIMATE INSTALLED WEIGHT per foot in pounds**

I.D.	G1A	G1+ G1C	G2+ G2C	G3+ G3C	G4+ G4C
06	6	7	9	11	13
07	7	8	10	12	15
08	7	9	11	13	16
09	8	9	12	14	17
10	9	10	13	16	19
12	10	12	15	18	21
14	12	14	17	20	24
16	13	15	19	22	26

I.D.	G1A	G1+ G1C	G2+ G2C	G3+ G3C	G4+ G4C
18	15	17	21	25	29
20	16	19	23	27	35
22	18	21	25	33	38
24	19	22	30	35	41
26	24	28	33	38	43
28	26	30	35	40	46
30	27	32	37	43	49
32	29	34	40	46	52

I.D.	G1A	G1+ G1C	G2+ G2C	G3+ G3C	G4+ G4C
34	31	36	42	48	55
36	33	38	44	51	57
38	39	45	51	58	65
40	41	47	54	61	68
42	43	49	56	64	71
44	45	51	59	66	74
46	47	54	61	69	77
48	49	56	64	72	80

**APPROXIMATE HEIGHT LIMITATION in feet**

I.D.	Model G1A					Model G1+ & G1C					Model G2+ & G2C					Model G3+ & G3C					Model G4+ & G4C				
	STR	TEE	PLS	WSA	VRS	STR	TEE	PLS	WSA	VRS	STR	TEE	PLS	WSA	VRS	STR	TEE	PLS	WSA	VRS	STR	TEE	PLS	WSA	VRS
06	313	105	394	243	125	264	88	333	205	105	204	68	257	159	81	161	54	203	125	64	130	44	164	101	52
07	286	102	359	216	113	242	86	304	183	96	188	67	236	142	74	149	53	187	113	59	122	44	153	92	49
08	264	100	331	193	102	222	84	278	162	85	173	65	217	127	67	140	53	176	103	54	115	44	145	85	45
09	243	97	305	173	93	205	82	257	146	79	162	65	203	116	62	132	53	166	94	51	110	44	137	78	42
10	229	95	287	159	85	194	81	243	134	72	153	64	192	106	57	126	53	158	87	47	105	44	132	73	39
12	207	93	258	136	75	173	78	216	114	63	140	63	175	92	51	115	52	144	76	42	97	44	121	64	35
14	188	91	226	118	66	159	77	191	99	56	130	63	156	81	46	108	52	129	67	38	91	44	109	57	32
16	176	90	203	105	60	148	75	171	88	51	121	62	140	72	42	101	52	117	60	35	86	44	100	52	30
18	163	78	182	93	55	138	66	154	79	46	114	54	127	65	38	96	46	107	55	32	82	39	91	47	28
20	155	69	168	85	51	131	59	142	71	43	108	49	117	59	36	92	41	99	50	30	71	32	76	39	23
22	148	62	155	77	47	125	53	131	65	40	103	43	108	54	33	78	33	82	41	25	68	29	71	36	22
24	142	56	145	71	45	120	47	122	60	38	88	35	89	44	28	76	30	77	38	24	66	26	67	33	21
26	117	40	116	57	36	101	35	100	49	31	85	29	84	41	26	73	25	73	36	23	64	22	63	31	20
28	113	33	109	53	34	98	29	94	46	30	83	24	79	39	25	72	21	69	33	22	62	18	60	29	19
30	110	27	103	49	33	95	24	89	43	28	81	20	75	36	24	70	17	65	31	21	61	15	57	28	18
32	106	22	97	46	31	92	19	84	40	27	78	16	72	34	23	68	14	62	30	20	60	12	55	26	18
34	104	17	93	42	29	90	15	80	36	25	77	13	68	31	21	67	11	59	27	19	59	10	52	24	16
36	102	13	89	38	27	88	12	77	33	23	75	10	66	28	20	65	9	57	25	17	58	8	50	22	15
38	88	12	74	30	22	78	10	65	27	19	68	9	57	23	17	60	8	50	21	15	53	7	45	18	13
40	88	11	71	28	20	77	10	63	24	18	67	9	55	21	16	60	8	48	19	14	53	7	43	17	12
42	88	11	68	25	19	77	10	60	22	17	67	9	53	19	15	60	8	47	17	13	53	7	42	15	12
44	87	11	66	23	18	77	10	58	20	16	67	9	51	18	14	60	8	45	16	12	53	7	40	14	11
46	87	11	64	21	16	77	10	56	18	15	67	9	49	16	13	60	8	44	14	11	53	7	39	13	10
48	87	11	62	19	15	77	10	55	17	14	67	9	48	15	12	60	8	42	13	11	53	7	38	12	10



## SECTIONS & FITTINGS

Van-Packer makes a wide range of prefabricated adapters, fittings, elbows, wyes, tees, transitions, increasers, terminations, etc. Refer to the Model GA & Gplus brochure for additional information on part number designations and the wide range of parts and fittings we offer to complete a system from start to finish. In general, all sections are assembled with a standard flange connection; however, below are a few examples of parts that may require special attention.

### ADAPTERS

Adapters connect to the liner flange per the joint assembly instructions.

**FAN/HOOD ADAPTER - PART FAS** is intended to be used with a roof curb (provided by others) connection to a hood or an exhaust fan. Field connect the plate to the hood, curb or fan (drilling / fasteners & sealant by others as required). Refer to the hood, fan unit or the roof curb manufacturer's installation requirements.

**STARTER SECTION - PART S/S** is a short liner piece flanged on each end. This part is intended to have one end connected to a hood, duct/transition, fan unit, etc.

**FLANGELESS OUTLET ADAPTER - PART FOA** is a split liner piece with draw-up tabs. This adapter is intended to be slipped over a smooth collar, then drawn tight with the included fasteners. Apply sealant to the outside of the smooth collar then slightly rotate the FOA as it is slipped over the collar prior to draw-up.

**BOLT FLANGE - PART BFA** is a short liner piece flanged on each end with a preassembled 1/4" thick van-stone (free floating) type bolt flange. This adapter is intended to be connected to a companion flange with appropriate fasteners (fasteners by others). Place a bead of sealant around flanged outlet about 1/8 inch from inside diameter

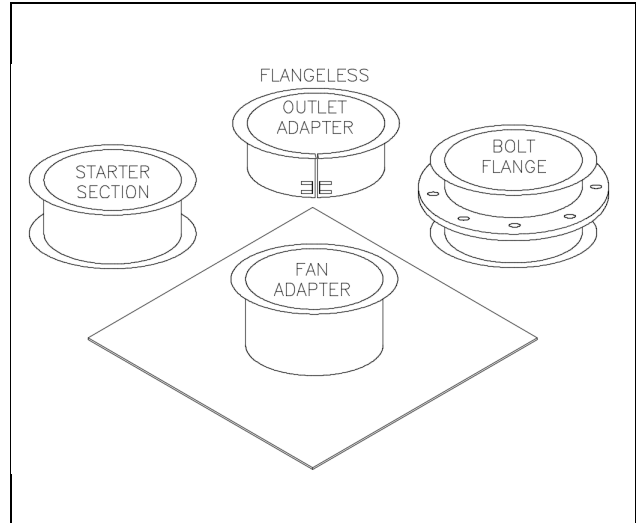

### FITTINGS & STRAIGHT SECTIONS

These fitting connect per the joint assembly instructions (page 6). Fittings and Straight sections are fixed degrees, lengths, etc., joined together to complete desired duct runs. These sections may also be equipped (must be factory installed) with nipples or couplings to accommodate test probes, drainage, etc. Refer to the Model GA & Gplus brochure for designation of part lengths and options for adding pipe nipples / couplings.

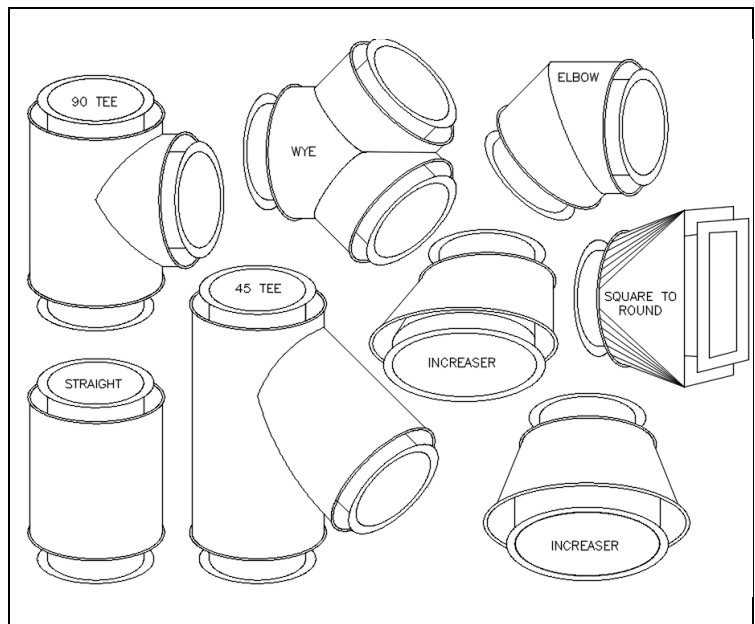

## SECTIONS & FITTINGS CONTINUED

### ACCESS PANEL & GREASE DRAINS

These fittings connect per the joint assembly instructions (page 6). Some uses for these fittings are: duct accessing, duct cleaning, grease drainage, test probes, sprinkler heads, fire suppression nozzles, etc. Please refer to the Model GA & Gplus brochure for additional information and part number designation.

#### PLEASE NOTE:

1. Never allow grease to puddle or accumulate in the system.
2. Drain piping cannot connect in a manner that adds additional weight/stress to our system.

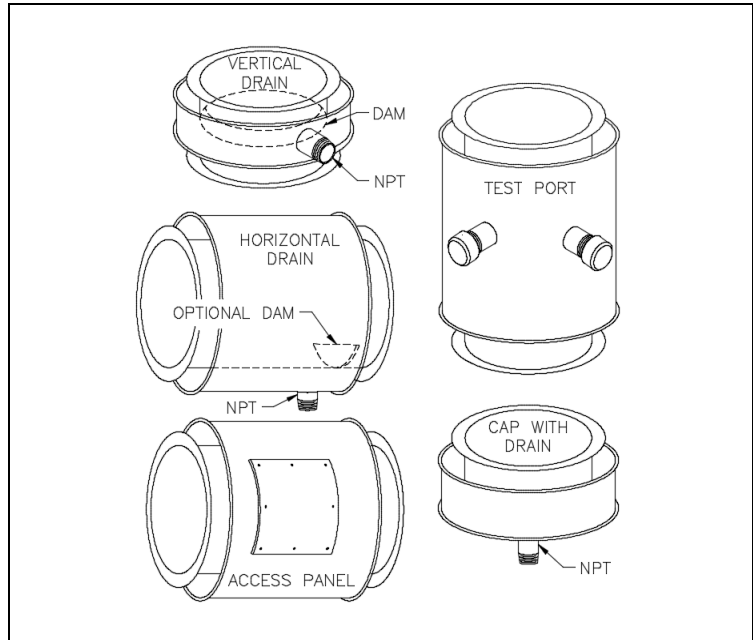

### TERMINATIONS

Terminations connect per the joint assembly instructions (page 6). See below for weatherproofing instructions. Van-Packer makes several terminations. Refer to the Model GA & Gplus brochure for additional information on part number designations and the wide range of parts we offer to complete a system.

**PLEASE NOTE:** When using a termination with a **RAIN SKIRT - PART RSK**. Bolt in place right below the vee band and put a bead of sealant at the seam and around the upper portion between the rain skirt and vee band for weatherproofing.

When using an **OPEN TOP CLOSURE - PART OTC** Bolt in place right below the flange and put a bead of sealant at the seam and around the upper portion between the OTC and flange for weatherproofing.

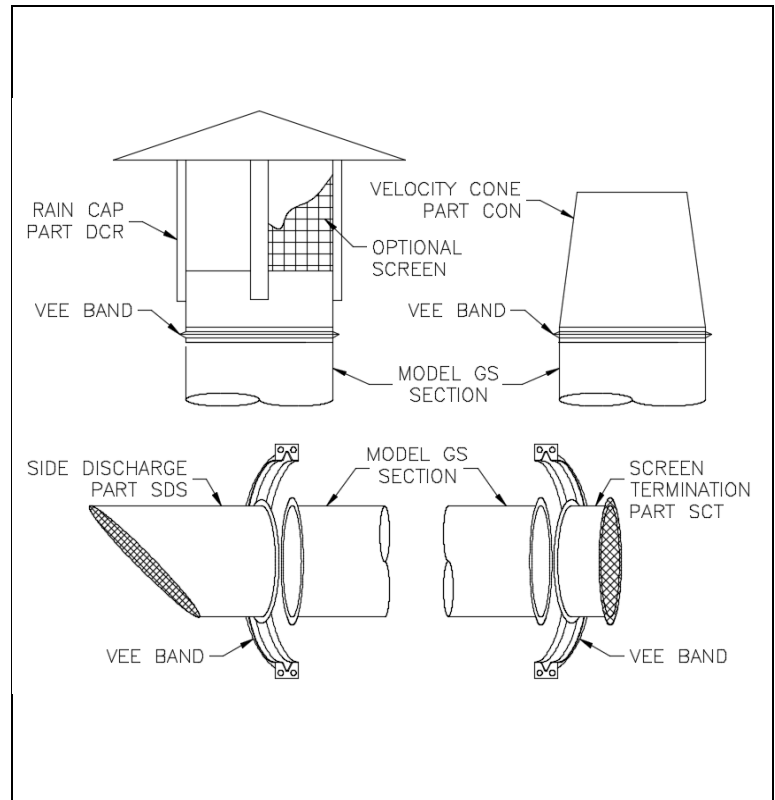

## SECTIONS & FITTINGS - CONTINUED

### ADJUSTABLE EXPANSION AND VARIABLE LENGTH SECTIONS

These components cannot be installed in series and are non-load bearing. For some installations, I.E. between two fittings, field cutting of the slip liner may be required. The raw end of the slip liner must slide into the mating section a minimum of 2", more is better. The raw end must always be down-hill from the rolled flange end. Do not cut slip liners to the exact "flange to flange" distance of the components being joined. Carefully cut and position slip liners accordingly when installed near tee sections, elbows, etc. as to not restrict/obstruct the flow of the duct system.

#### NOTES:

1. Apply sealant per the pictures to the right and the joint assembly instructions.
2. On the variable length section remember to slide the locking collar on the slip liner before step 3.
3. Slide the slip liner into the previous installed section before installing the following sections.
4. Wrap the assembly with the provided insulation. If Model Gplus series.
5. Complete the duct enclosure by positioning the cover so that it overlaps the shells of the adjoining components and draw-up with the provided fasteners.

#### PART – ADJ

Adjustable expansion section is intended to be used to span distances between 1-1/2" to 19-1/2" and compensates for thermal expansion. These components are comprised of a slip liner and rope gasket.

#### PART – VLS

Variable length sections are intended to be used to span distances between 4-1/2" to 19-1/2". These components are comprised of a slip liner and locking collar. This part simulates a custom length straight section.

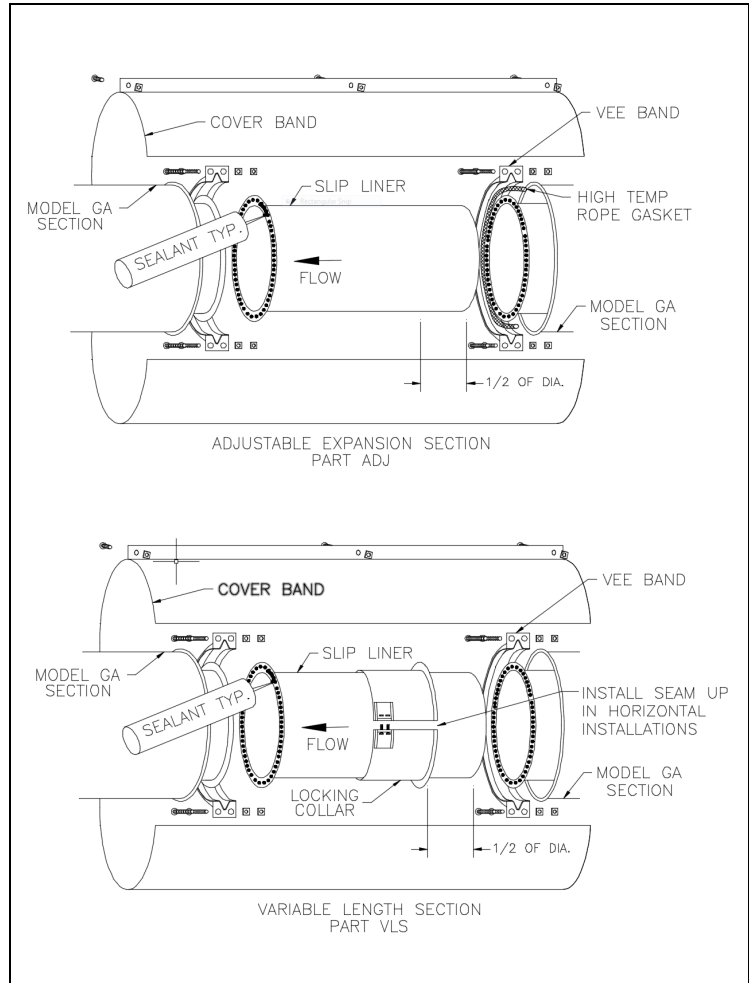

#### COVER PLATE – PART CVR

Van-Packer offers cover plates to close off the space between the liner and the shell. Use this to hide the liner and/or insulation from sight. Example shown below is installing the cover plate on a 90 tee projection.

#### STEP 1

Install the cover plates per the picture to the right. Self-tapping screw can be used to hold the two halves into place.

#### STEP 2

Fasten the half draw bands in place like the joint assembly instructions page 6 STEP 8

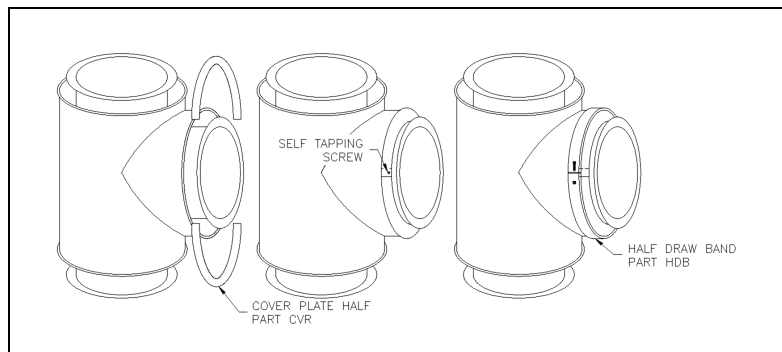

## SUPPORTS & GUIDES

NOTES: The structural engineer for the project should select support member channels, beams, rods, wires/cables, etc. and joining methods in accordance with *Good Engineering Practices* to suite each specific application. Rods, wires/cables should only be used for hangers, NOT structural supports. Van-Packer accepts no responsibility for the design and/or modification of buildings or structures to accept the given load. All support framing, anchoring methods, etc. are by others.

### STRUCTURAL SUPPORTS

#### PLATE SUPPORT ASSEMBLY – PART PLS

Plate support assemblies are used for vertical & horizontal structural anchor points. The PLS is to be used with structural support members, which are designed by the building structural engineer, not Van-Packer. Refer to page 7 for structural support limitations.

#### NOTE

The PLS consists of 6 pieces, 2 rectangular support plates, 2 round clamp flange halves and 2 half draw bands. The PLS, in conjunction with field fabricated support members, provides support for the duct (The seam in the S/P must be rotated 90 degrees from the C/F seam)

#### STEP 1

Apply sealant on the liner flange. Join the two liners together (no Vee Band is required) to capture the flanges between the support plate and the clamp flange. Bolt together the S/P and the C/F with the 3/8" bolts provided. Fully tighten the bolts.

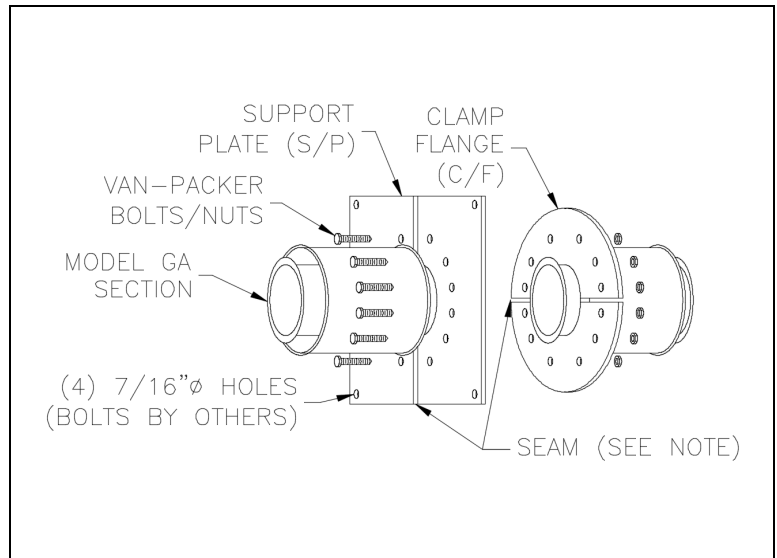

#### STEP 2

Refer to joint assembly instructions page 6 STEP 7

#### STEP 3

Fasten the half draw bands in place like the joint assembly instructions page 6 STEP 8

#### STEP 4

Support all four sides of the support plate. Design support member and fasteners in accordance with good engineering practices to suit each specific application. Van-Packer assumes no responsibility for the design and/or modification of buildings or structures to accept the given loads

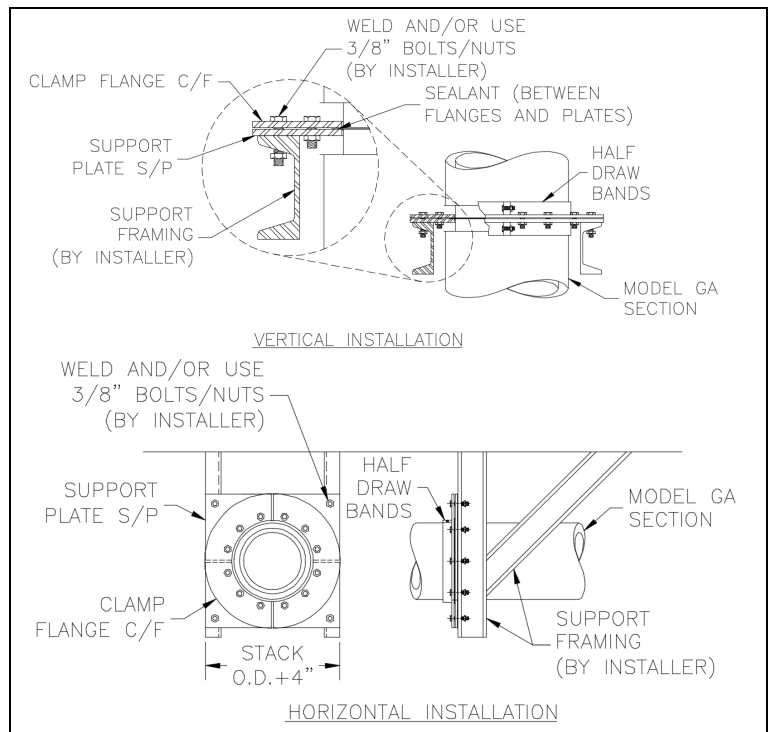

## SUPPORTS & GUIDES - CONTINUED

### WALL SUPPORT – PART WSA

The wall support (WSA) is intended to provide a rigid support location. In some instances, additional field fabricated support members from the building wall structure to the wall bracket may be required. Anchor bolts and design by others. This rigid support location is intended to withstand the weight of duct components, forces from thermal expansion & exhaust velocities, etc. Design support member and fasteners in accordance with good engineering practices to suit each specific application. Van-Packer assumes no responsibility for the design and/or modification of buildings or structures to accept the given loads. Do not install near combustible material. Refer to chart on page 7 for support limitations.

#### NOTE:

The WSA consists of 6 pieces, 2 wall brackets, (left and right), 2 bottom plates, 2 top plates and 2 half draw bands.

#### STEP 1

Apply sealant on the liner flange. Join the two liners together (no Vee Band is required) to capture the flanges between the top and bottom plates. Bolt together the top and bottom plates with the 3/8" bolts provided. Fully tighten the bolts. These plates install just like the plate support assembly (page 11)

#### STEP 2

Refer to joint assembly instructions page 6 STEP 7

#### STEP 3

Fasten the half draw bands in place like the joint assembly instructions page 6 STEP 8

#### STEP 4

Anchor the wall brackets to the wall or additional field fabricated support members accordingly.

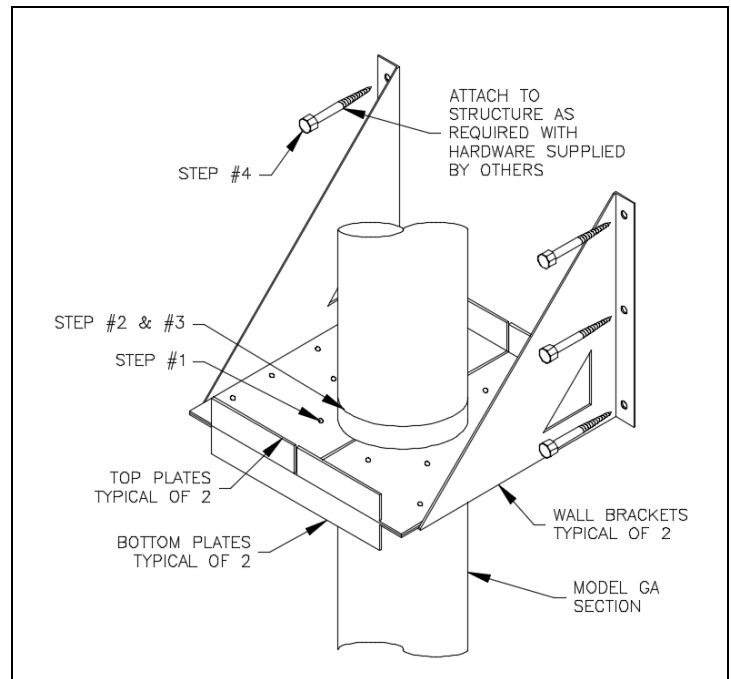

### HORIZONTAL SUPPORT HANGER

Horizontal Hanger Supports, support the weight of horizontal assembled duct lengths while also maintaining alignment as the duct expands and contracts. Use hangers in conjunction with support rods or other field fabricated support members that attach to the building or structure. Position hanger away from joint to allow for unrestricted expansion and contraction of the chimney/vent system.

**PART FAR** supports horizontal and vertical length of duct in all diameters and models.

**PART HAR** supports horizontal lengths of pipe 24" I.D. and under for all models.

**PART BHB** supports horizontal length of pipe 24" I.D. and under for models GA & Gplus.

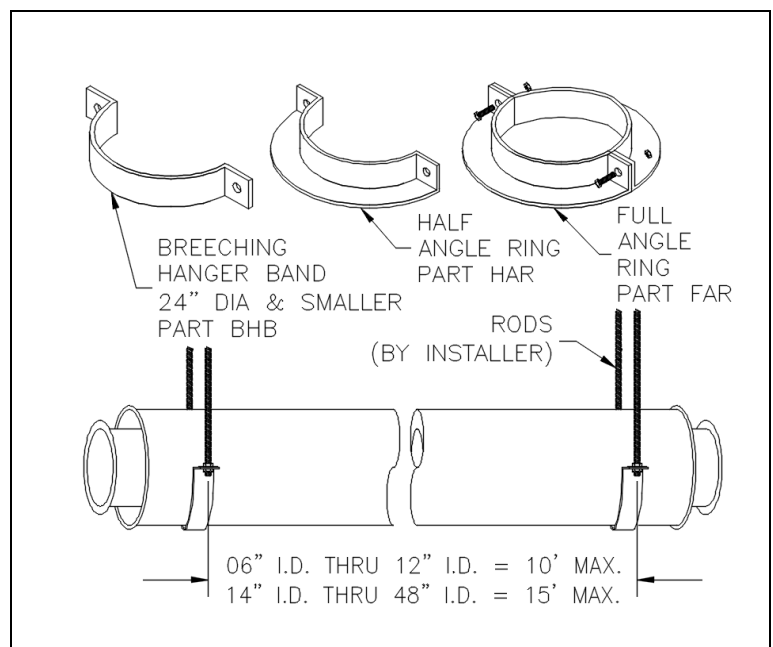

## SUPPORTS & GUIDES - CONTINUED

### LATERAL BRACES

#### FULL ANGLE RING – PART FAR

Full angle ring, in conjunction with field fabricated support members from the FAR attached to the building or structure, are intended to laterally brace the vertical assembled duct lengths from wind loads and to also maintain alignment. The FAR is comprised of (2) halves when bolted together fit loose around the duct to allow for expansion and contractions. Position the FAR away from the joint to allow for unrestricted expansion and contraction of the duct system.

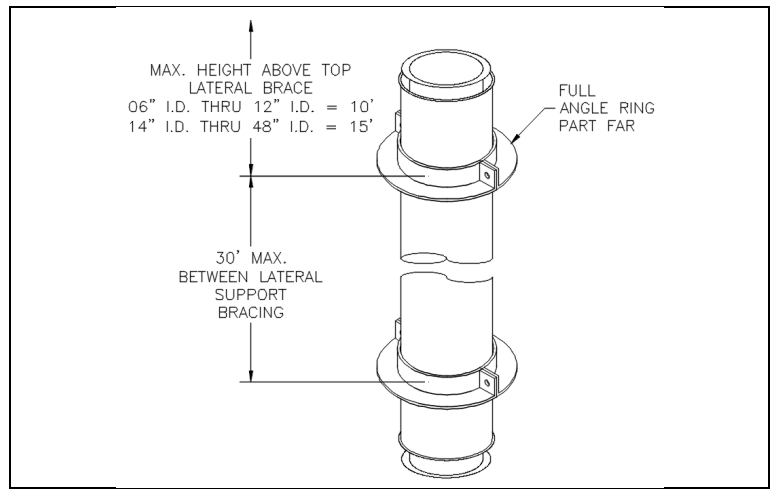

#### GUY ATTACHMENT RING – PART GAR

Guy attachment ring, in conjunction with cables, tensioners, anchors, and other miscellaneous hardware from the GAR attached to the building structure, are intended to laterally brace the vertical assembled duct lengths from wind loads and to also maintain alignment as the duct expands and contracts.

#### NOTE

The GAR consists of 4 clamp flanges and 2 half draw bands. (Do NOT line up seams of the clamp flanges. They should be rotated by 90 deg). Minimum of three cables spaced at 120 deg apart is required for one GAR. Cables, anchors and all other miscellaneous hardware is by installing contractor. Please note the cables must have tension on them at all times. (Do not over tension the wires) Some type of a tensioner must be used to keep the cables tight while still allowing for expansion and contraction

#### STEP 1

Apply sealant on the liner flange. Join the two liners together (no Vee Band is required) to capture the flanges between the clamp flanges. Bolt together the flanges with the 3/8" bolts provided. Fully tighten the bolts

**STEP 2** Refer to joint assembly instructions page 6 **STEP 7**

#### STEP 3

Fasten the half draw bands in place like the joint assembly instructions page 6 **STEP 8**

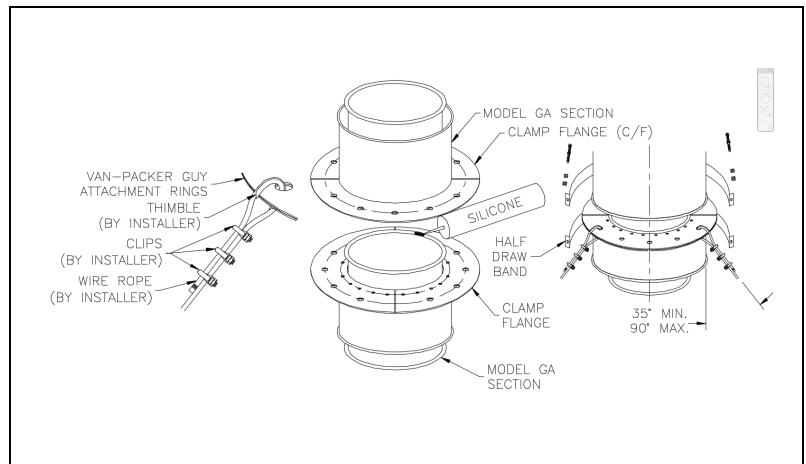

#### GUY TENSIONER – PART 1500GUY

Van-Packer offers a 1500 pound Guy Tensioner that is good for up to 3" of expansion. Use the guy tensioner in conjunction with the guy attachment ring. The guy tensioner allows you to keep tension on the guy cables while still allowing for expansion and contraction. Cables, anchors, and other miscellaneous hardware is to be by the installing contractor. (Do not over tension the wires.)

**NOTE:** Van-Packer accepts no responsibility for the design and/or modification of buildings or structures to accept the given load.

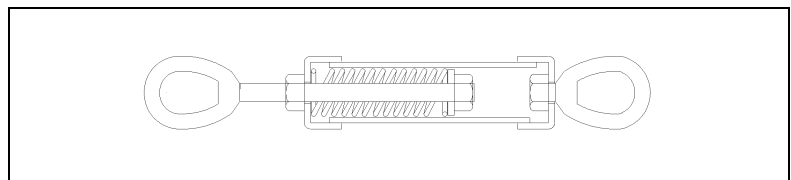

## ROOF PENETRATIONS

### INSULATED THIMBLE, FLASHING, & COUNTER FLASHING - PARTS THM, FLS, & CFL

Insulated thimbles and flashings are available for flat and many pitched roofs. The roof pitch must be specified at the time of purchase as these components are NOT adjustable. The required roof opening (square or round opening allowed) for a flat roof is duct O.D. +8 1/2".

#### STEP 1

Cut the roof opening. If no thimble is being used, skip to **STEP 2** below. Lower the thimble through the opening and mount to the roof/curb with appropriate fasteners (by others) at all mounting holes. **NOTE:** do not block the airflow between the thimble and the venting system.

#### STEP 2

Center the flashing around the thimble, attach and weatherproof it to the roof/curb with appropriate fasteners and weatherproofing material (by others). **NOTE:** Consult the roofing contractor.

#### STEP 3

Assemble the duct through the thimble accordingly. Next, install the counter flashing by positioning it around the duct and against the screen at the top of the flashing. Then, with the provided fasteners draw up the counter flashing. Last, apply a bead of sealant at the top of the counter flashing. **NOTE:** roofing materials must not fill the entire space between the roof and the bottom of the counter flashing.

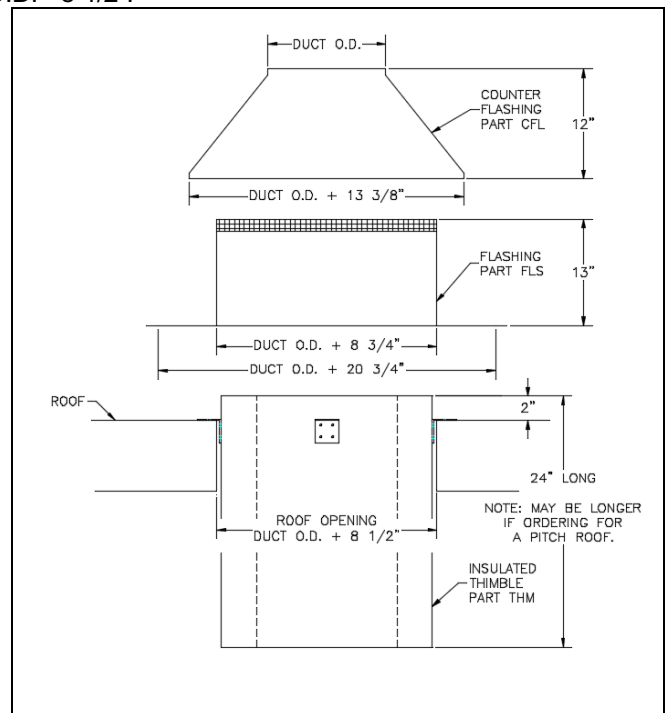

### VENTILATED ROOF PENETRATION ASSEMBLY – PART RPA or VRT

The ventilated roof penetration assembly can be used when the duct passes through a flat roof or a pitched roof with a level roof curb. The required rough roof opening is duct O.D. +10".

The **RPA** is comprised of (1) ventilated roof thimble VRT, (1) flashing FLS, and (1) counter flashing CFL.

The **VRT** is comprised of (1) ventilated roof thimble VRT, (1) flange support assembly FSA, (1) flashing FLS, and (1) counter flashing CFL. **Note:** The VRS supports vertical load only. Duct must be properly laterally braced. The structural engineer for the project must verify the roof/curb are capable of supporting the intended load.

#### STEP 1

Cut the rough roof opening. If no thimble is being used, skip to **STEP 2** above. Lower the thimble through the opening and mount to the roof/curb with appropriate fasteners (by others) at all mounting clip holes. **NOTE:** do not block the airflow between the thimble and the venting system. Then install the flashing and counter flashing in accordance with instructions **STEPS 2 & 3** above.

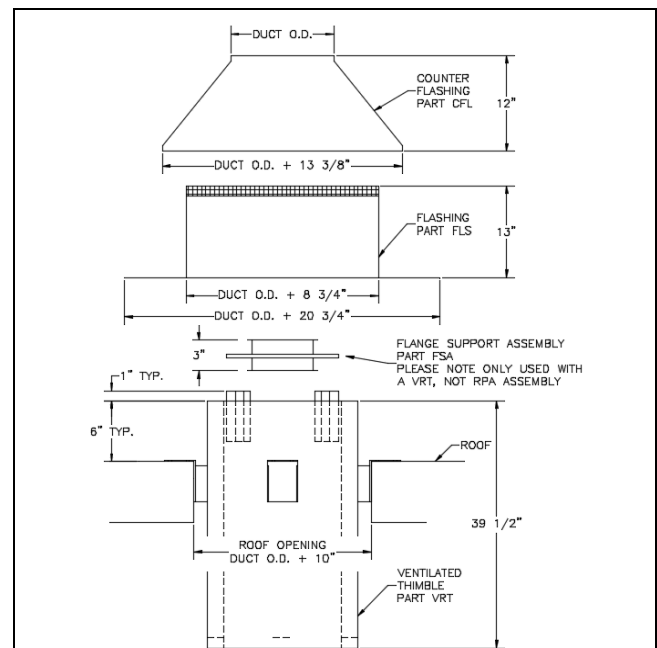

## SYSTEM INSTALLATION EXAMPLE

Below shows an installation example. This example is intended to reflect general requirements for support locations, with respect to fittings and to also show standard support locations for an installation in accordance with its design listing. This example may not reflect all necessary supports, drains, etc. which may be required to meet applicable codes and to help ensure a well functioning duct system (refer to applicable codes as required).

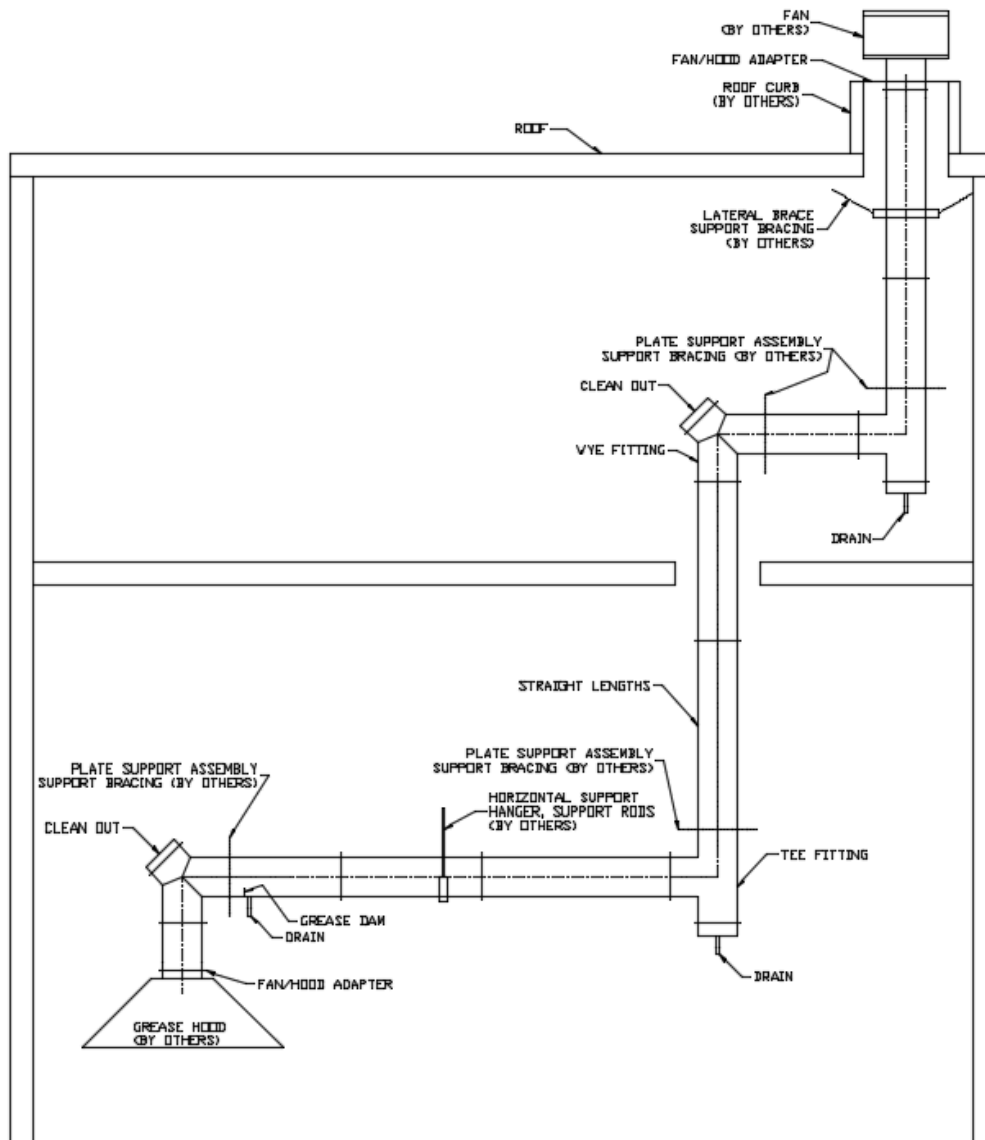

Van-Packer Company  
Sales, Service and Manufacturing  
302 Mill Street, PO Box 307  
Buda, Illinois 61314-0302  
Phone 1-888-VPSTACK (1-888-877-8225) or 1-309-895-2311  
Fax 1-309-895-3891  
Tech Email [vpstech@vpstack.com](mailto:vpstech@vpstack.com)  
Web Site [www.vpstack.com](http://www.vpstack.com)

GA Installation Guidelines 08/10/21