

CO., INC.

MODEL GRZ

Zero Clearance Grease Duct Installation Guidelines

Tested to UL1978/ULCS662, UL2221/ULC S144, ULC/S115 & ASTM E814

TABLE OF CONTENTS

LISTING & CODE COMPLIANCE	3
TESTING, CLASSIFICATION, & APPLICATIONS.	3
GENERAL INFORMATION	3-5
CLEARANCES & ADDITIONAL ENCLOSURES	3
CODES & AUTHORITIES.	3
INSTALLATION CONSIDERATIONS	3-4
MIXING SYSTEMS & PARTS.	4
DUCT SIZE & SLOPE.	4
CLEANOUTS, DRAINS, & GREASE TRAPS	4
WASH DOWN & FIRE SUPPRESSION.	4-5
RECEIVING INSPECTION	5
TYPICAL COMPONENT LOCATIONS	5
FREIGHT DAMAGE.	5
PART IDENTIFICATION & MATERIAL CODES	5
JOINT ASSEMBLY	6-7
SEALANT USAGE.	7
INSTALLED WEIGHT CHART.	7
SUPPORT LOAD LIMITATIONS.	7
DRAW BAND FASTENERS	9
INSULATION - STRIP WIDTHS & FIRE STOP PACKING	9
DUCT SECTIONS & FITTINGS	7-9
APPROX WEIGHT PER FOOT	7
ADAPTERS	8
STRAIGHTS	8
ELBOWS, TEES, TRANSITIONS	8
ACCESSORIES	8
TERMINATIONS.	9
SUPPORTS & GUIDES.	9-12
SUPPORT LOAD LIMITATIONS.	7
STRUCTURAL SUPPORTS.	9-11
BREECHING SUPPORTS.	12
LATERAL BRACES & GUIDES.	12
PENETRATIONS & FIRESTOPS.	13-14
FLOOR / CEILING THROUGH PENETRATION FIRESTOP.	13
WALL THROUGH PENETRATION FIRESTOP	14
FLOORS / CEILINGS & WALLS - FIRE RATING NOT REQUIRED	15
ROOF PENETRATIONS	15
SYSTEM INSTALLATION EXAMPLE.	16

LISTING & CODE COMPLIANCE

Van-Packer's Model GRZ grease ducts are listed by Intertek as a "zero clearance grease duct enclosure assembly" and as "*Grease Ducts for Restaurant Cooking Appliances*" when installed in accordance with its Intertek listings, these instructions, and the National Fire Protection Association's standard NFPA 96 "*Standard for Ventilation Control and Fire Protection of Commercial Cooking Operations,*" International Mechanical Code, Uniform Mechanical Code, or other local codes.

TESTING, CLASSIFICATION, & APPLICATIONS

Model GRZ has been tested in accordance with the procedures and methods set forth by UL 2221 /ULC S144 (*Tests for Fire Resistive Grease Duct Enclosure Assemblies/Standard Method of Fire Resistance Test-Grease Duct Assemblies*), UL 1978/ULC S662 (*Standard for Grease Ducts/Standard for Factory-Build Grease Ducts*), and ICC-ES AC101.2 (*Acceptance Criteria for Grease Duct Enclosure Assemblies:Segmented Grease Duct Systems*). Model GRZ with stainless steel liner is qualified as an alternate to a 2 hour rated fire resistive shaft enclosure; eliminating, in most applications, the requirement for a separate fire resistive enclosure. Model GRZ with mild steel liner is also qualified for a 2 hour fire resistance rating based on CAN/ULC S144, and is qualified for a 1 hour fire resistance rating based on ICC-ES AC101.2. Model GRZ grease ducts are suitable for the removal of smoke and grease laden vapors from commercial, industrial, institutional, and similar cooking applications where continuous operating temperatures are 500° F (260° C) or less and for intermittent temperatures not exceeding 2000° F (1093° C). Model GRZ grease ducts are intended to be part of a complete grease duct system which connects the hood or grease extractor with the outdoors by means of an exhaustor or blower system.

GENERAL INFORMATION

CLEARANCES & ADDITIONAL ENCLOSURES

The clearance to non-combustible materials is zero inches. Where components are insulated and enclosed by their respective shell, cover, or draw band for all installations except within a completely enclosed non-ventilated combustible enclosure the clearance to combustible materials is zero inches.

WARNING: Code compliant clearances must be followed where any uninsulated components that are in direct contact with the liner and the component penetrates through the insulation and exits past (or through) the duct shell or draw band. Examples of this would be support assemblies, drain pipes, or any other similar items. Do not install these items near combustible material.

When installed in accordance with these instructions and codes, Model GRZ grease ducts are equivalent to field fabricated two hour fire rated grease duct enclosure systems. Do not apply wraps or enclosure materials in direct contact with Van-Packer's products in a manner that adds additional weight to our duct. Model GRZ has not been tested, listed, designed, etc. to carry additional weight from such materials.

CODES & AUTHORITIES

Installation must be made in accordance with local and national code requirements. Follow these instructions carefully and contact local building and fire officials about restrictions and installation inspection in your area. Refer to NFPA 96 (*Standard for Ventilation Control and Fire Protection of Commercial Cooking Operations*) and additional NFPA standards as required.

INSTALLATION CONSIDERATIONS

Follow Van-Packer's written installation instructions carefully. Each part of the grease duct system must be installed correctly. Improper or lack of installation of required parts may result in the improper function of the grease duct system.

The grease duct layout should be carefully planned to allow adequate space for assembly, installation of supports, connection of support framing, access for cleanouts, accommodate standard fitting dimensions, rough openings for penetrations, etc. Do not assume all equipment producing smoke or grease laden vapors within a facility can be exhausted with a single grease duct system. Consult a grease duct design professional as required.

GENERAL INFORMATION

INSTALLATION CONSIDERATIONS- CONTINUED

One prime coat and finish coat of appropriate heat resistant paint is recommended on exposed installations which are subject to routine cleaning (*e.g. kitchen area*) and wherever exposed to the weather when the outer shell of components or accessories is constructed from aluminized steel.

Sealing of draw bands, overlapped or butted seams, etc. with an appropriate sealant is recommended on exposed installations which are subject to routine cleaning (*e.g. kitchen area*) and wherever exposed to the weather in order to avoid moisture from entering the space between the grease duct shell and liner.

MIXING SYSTEMS & PARTS

Do not connect a grease duct system with any other building ventilation or exhaust system. Do not connect parts from other grease duct manufacturers with Model GRZ components without the expressed consent of Van-Packer.

Components from other Van-Packer product lines, (for example Model GZ), may be mixed with Model GRZ components to complete a grease duct system as long as: clearances, limitations, codes, etc. are followed. Contact Van-Packer for more information concerning product lines which are listed for use as grease ducts.

Van-Packer grease duct components are designed to complete the entire system. However, we realize conditions occur where systems must be mixed. In these cases, in accordance with *good construction methods and codes* it is permissible to transition to/from a code compliant grease duct system (by others) to/from Van-Packer grease duct components. Connection must be an approved joint assembly method as described within installation instructions, and/or applicable codes. Transition (by others) cannot connect in a manner that adds additional weight/stress to our duct. Van-Packer's products have not been tested, listed, designed, etc. to carry additional weight from such transitions. **WARNING:** Listings / warranties may be affected when transitioning to / from grease ducts by others; consult Van-Packer technical service department for additional information.

DUCT SIZE & SLOPE

Model GRZ grease ducts must be installed accordingly to comply with the requirements as described in order to maintain a listed installation. UL 2221 standard (*Tests for Fire Resistive Grease Duct Enclosure Assemblies*) states that these grease ducts must comply with requirements as set forth by UL 1978 (*Standard for Grease Ducts*), NFPA 96 (*Standard for Ventilation Control and Fire Protection of Commercial Cooking Operations*), and the International Mechanical Code. Model GRZ grease ducts should be installed at a slope not less than 1/8 unit vertical in 12 units horizontal toward the hood or toward a grease reservoir. Where horizontal ducts exceed 75 feet in length, the slope shall be not less than 1/2 unit vertical in 12 units horizontal. Most Model GRZ components will permit a small amount of slope as the system is being installed. However, some installations may require elbow / transition type pieces to allow for proper orientation of fittings at the vertical risers prior to and after long horizontal runs. It is also acceptable for ducts to have staggered sloped (*e.g.*, uphill to a peak point, then downhill to a valley point), the distance between a valley point and peak point must follow the limitations above and every valley must allow for grease drainage (*i.e.*, a hood or reservoir). Contact Van-Packer for additional information.

CLEANOUTS, DRAINS, & GREASE TRAPS

Many Model GRZ sections, accessories, and combinations can be used for cleanout and inspection access of the grease duct system. Access panel sections, 90° tee sections with end caps, and many other combinations of components can serve as cleanout doors or openings as described by NFPA 96. Grease ducts must be provided with adequate cleanout doors or openings to allow for the inspection and cleaning of the entire grease duct system. Refer to NFPA 96 for specific requirements.

Cleanout, drain, and grease trap requirements may change when grease duct systems are equipped with automatic cleaning and / or some types of fire suppression equipment. Refer to NFPA 96 and additional codes / authorities having jurisdiction for specific duct system requirements.

WASH DOWN & FIRE SUPPRESSION

Automatic hot water / detergent wash down and fire suppression systems can be integrated into a Model GRZ grease duct system by using various components which are readily available (or by request sections can be factory fit) with threaded pipe nipples, couplings, etc.

GENERAL INFORMATION

WASH DOWN & FIRE SUPPRESSION- CONTINUED

Van-Packer does not provide, design, specify, etc. wash down and fire suppression equipment or systems. Refer to NFPA 96 and additional codes / authorities having jurisdiction for specific fire suppression system requirements. Some of the various types of fire extinguishing equipment / systems are: Carbon Dioxide (NFPA 12), Sprinkler (NFPA 13), Foam-Water (NFPA 16), and Dry Chemical (NFPA 17).

RECEIVING INSPECTION

Compare the packing list items and quantities with the contents of the containers to ensure completeness of the shipment. If the shipment is missing components, please contact Van-Packer's order entry department at 888 877 8225.

TYPICAL COMPONENT LOCATIONS

Straight sections, fittings, etc. will be positioned and stacked accordingly to fill the shipping container. Sections of smaller dimensions may be slipped into sections of larger dimensions. Bags of fasteners, sealant, etc. may also be located inside the liner of the various pieces.

FREIGHT DAMAGE

Inspect each box as it is unloaded from the carrier for damage which may have occurred during transit. Should there be any damaged components, the delivery receipt must be signed damaged in order for Van-Packer to file a claim with the carrier. If the delivery receipt is signed damaged contact Van-Packer immediately. If there are damaged parts and the delivery receipt is not signed damaged, Van-Packer or the carrier will not be liable, and damaged parts will be replaced at the customer's expense.

PART IDENTIFICATION & MATERIAL CODES

Model GRZ part numbers will typically have the letter "GRZ" prefix, followed by the duct size inside dimension (I.D.), then the part description code, next a special qualifier code(s) and last the liner/shell designation. Part description codes are generally three characters and are either alpha or alpha numeric. Qualifier codes are most often used to designate section lengths, tee projection dimensions, and the large I.D. end of increasers. The following are a couple examples of part numbers with their associated description and part number breakdown.

GRZ12X10STR30CL

Refers to a Model GRZ 12"X10" I.D., 30" long straight section constructed with a 430 S.S. liner and an aluminized steel shell.

GRZ = Model GRZ
12x10 = Section I.D.
STR = Part Code, Straight Section
30 = Section length, 30" long
C = Liner Code, 430 S.S.
L = Shell Code, ALZ Steel

GRZ12X1290T08X08CC

Refers to a Model GRZ 12"X12" I.D. 90 degree centered tee section with an 08" x 08" I.D. projection constructed with a 430 S.S. liner and a 430 S.S. shell.

GRZ = Model GRZ
12x12 = Tee Body, 12"x12" I.D.
90T = Part Code, 90 Degree Tee Section
08x08 = Tee Projection, 08"x08" I.D.
C = Liner Code, 430 S.S.
C = Shell Code, 430 S.S.

LINER MATERIAL CODES

C = 430 S.S.

SHELL MATERIAL CODES

C = 430 S.S.
L = Aluminized Steel

Other material types and/or material thicknesses are available, however using non-standard material types/thicknesses may extend the delivery, always consult the factory for availability

JOINT ASSEMBLY

According to NFPA 96, all grease ducts are to be liquid tight. The following steps are to be used to ensure this requirement is met.

Use high temperature silicone sealant, Van-Packer part number 101087A. **WARNING:** Do not substitute any type of water soluble sealants in the flange area.

STEP 1

Inspect all liner flanges, and draw bands and straighten any mild deformations that may have occurred during shipping.

STEP 2

To ensure sealant adhesion, degrease and remove any dirt and debris from the liner flanges. Use an acetone based cleaner sprayed on a rag.

STEP 3

Apply a continuous bead of sealant (1/8" to 1/4") to one or both of the liner flanges to be joined.

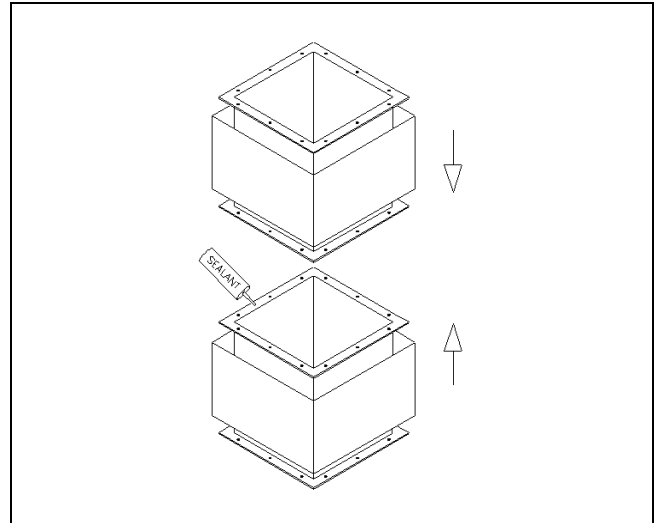

STEP 4

Butt the flanged ends of the sections being joined, being careful not to smear off the sealant.

Install all supplied bolts/nuts finger tight. After all bolt/nuts are installed on a joint snug them up. After everything is snug finish tightening all bolts to an approx. torque of 4 ft-lb, per bolt manufactures recommended bolt torque.

Remove / wipe smooth any excess sealant on the inside of the assembled duct.

Allow sealant to cure 7 days before use. Sealant will not bond to flanges if moisture is introduced into system before sealant has cured.

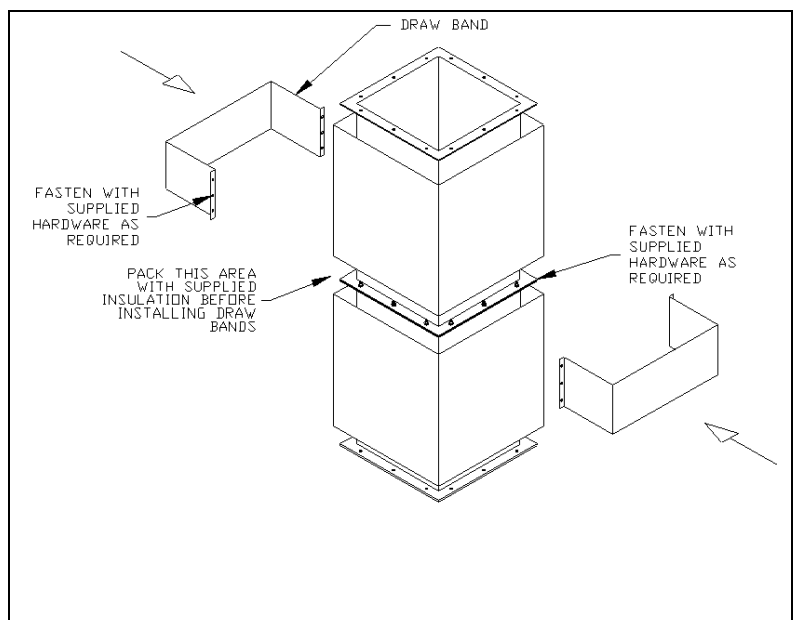

STEP 5

With the provided insulation strip, wrap the assembled joint (3) times completely with a 2" overlap at the end of the last wrap. Wrap the joint tight enough for the insulation to fit snug in the space between the liner & shell. *(This method applies wherever a joint requires to be wrapped prior to installing a draw band or cover.)*

STEP 6

Complete the grease duct enclosure by placing the draw band around and overlapping the shell flanges of the assembled components. With the provided fasteners and appropriate tools draw up the band accordingly. It is recommended that sealant (provided by others) be applied to the draw band edges to prevent moisture from entering between the duct walls on all sections exposed to the atmosphere. As necessary, self tapping screws can also be used to help seal the draw band to the outer shell. (provided by others). Recommended to have a minimum of two screws, per band, in the vertical run.

FLANGE / DRAW BAND FASTENERS

The fasteners provided with the flange are standard ¼"-20 hex bolts and nuts. Draw band fasteners are ¼" – 20 philips pan head screws with square nuts. Fittings come standard with draw band/cover, the fasteners provided for the flange will be plated steel. The provided fasteners for draw band/cover will be plated steel (where the shell is aluminized steel) or stainless steel (where the shell is stainless steel).

INSULATION - STRIP WIDTHS & FIRE STOP PACKING

Where the finished duct assembly uses a draw band (part GRZ**DRW*) a 4" wide roll of strip insulation is provided. Draw bands are typically used wherever standard fittings are assembled in series (most fittings are provided with a draw band and roll of insulation strips).

Where the duct penetrates through a wall or floor: a Fire Stop Penetration is to be used, the insulation for packing the opening is provided in 48" wide strips (*the factory may provide 24" wide strips, or a package/container of insulation marked as "Fire Stop Packing Material" or "Fire Stop Insulation" as an alternate*).

SEALANT USAGE

DUCT INTERNAL AREA SQ IN (INSIDE DIMENSION)	JOINTS PER TUBE
36 (6"X6")	20
72 (6"X12")	13
108 (6"X18")	10
144 (6"X24")	8
216 (6"X36")	6
288 (12"X24")	5

DUCT INTERNAL AREA SQ IN (INSIDE DIMENSION)	JOINTS PER TUBE
432 (12"x36")	5
648 (18"x36")	4
864 (24"x36")	4
1088 (32"x34")	3
1296 (36"x36")	3

APPROXIMATE INSTALLED WEIGHT PER FOOT

DUCT INTERNAL AREA SQ IN (INSIDE DIMENSION)	POUNDS
36 (6"X6")	18
72 (6"X12")	24
108 (6"X18")	29
144 (6"X24")	35
216 (6"X36")	41
288 (12"X24")	47

DUCT INTERNAL AREA SQ IN (INSIDE DIMENSION)	POUNDS
432 (12"x36")	52
648 (18"x36")	58
864 (24"x36")	64
1088 (32"x34")	71
1296 (36"x36")	75

SUPPORT LOAD LIMITATIONS

- Plate Support Assembly** (PLS, see page 10) can hold a maximum of 2,400 pounds.
- Flange Support Assembly** (FSA, see page 11) can hold a maximum of 3,400 pounds.
- Horizontal Angle Supports or Unistrut Supports** (see page 12) can hold a maximum of 500 pounds.
- Horizontal Hanger Bands** (BHB, see page 12) can hold a maximum of 420 pounds.
- Wall Brackets**, please see chart below and page 11.

BRACKET SIZE	LBS.
4"-32"	1300
34"-48"	900

Please use chart above for converting pounds into maximum feet. Please note installed weights above are based on straight runs, please take into consideration weight per foot may vary for some fittings etc.

DUCT SECTIONS & FITTINGS

Van-Packer makes a wide range of prefabricated adapters, fittings, elbows, wye's, tee's, transitions, increasers, terminations, etc. Refer to the Model GRZ brochure for additional information on part number designations and the wide range of parts and fittings we offer to complete a system from start to finish. In general all sections are assembled with a bolt flange connection; however, below are a few examples of parts that may require special attention.

FAN/HOOD ADAPTER ASSEMBLY – PART FAA

The fan adapter assembly is intended to be used with a “traditional” roof curb (provided by others) and connection to a hood or an exhaust fan. The FAA is comprised of a fan adapter plate (specify plate size at time of purchase) with a factory installed starter section that assembles to a standard fitting. Field connect the plate to the hood, curb or fan by (drilling / fasteners & sealant by others as required). Refer to the hood, fan unit or the roof curb manufacturer's installation requirements.

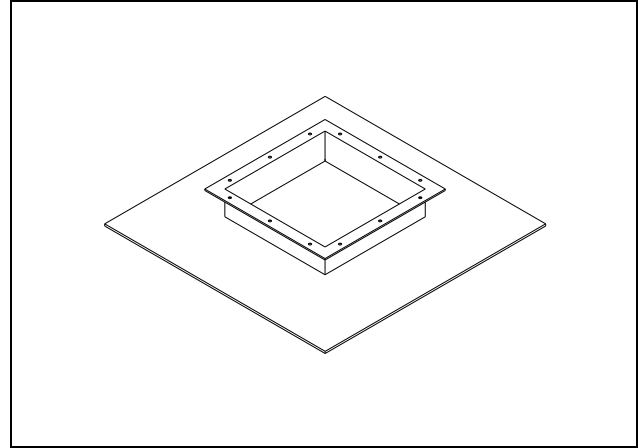

FITTINGS & STRAIGHT SECTIONS

Fittings and Straight sections are fixed degrees, lengths, etc., joined together to complete desired grease duct runs. These sections may also be equipped (must be factory installed) with nipples or couplings to accommodate test probes, fire suppression nozzles, sprinkler heads, drainage, etc. Refer to the Model GRZ brochure for designation of part lengths and options for adding pipe nipples / couplings.

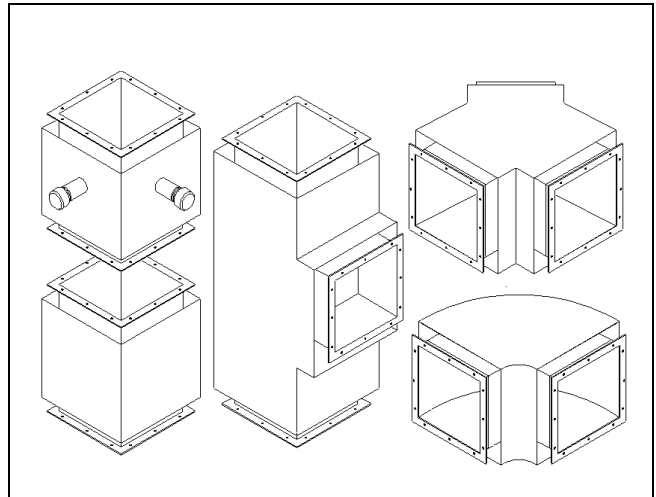

ACCESS PANEL SECTION – PART APS

This part is intended to be used for clean out access. When the access panel section is installed in a horizontal position, it must be orientated in accordance with applicable codes. Please refer to the Model GRZ brochure for additional information and part number designation.

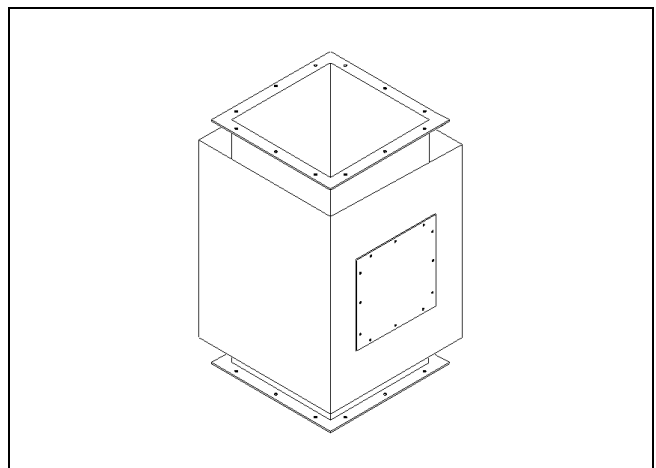

DUCT SECTIONS & FITTINGS CONTINUED

OPEN TOP CLOSURE – PART OTC

The open top closure covers the space between the liner and shell. First, position the OTC around the liner. Next, butt the OTC up against the flange of the liner and using the provided fasteners draw up the OTC. Last, apply a bead of sealant at the seam formed between OTC and the liner to form a weather tight seal.

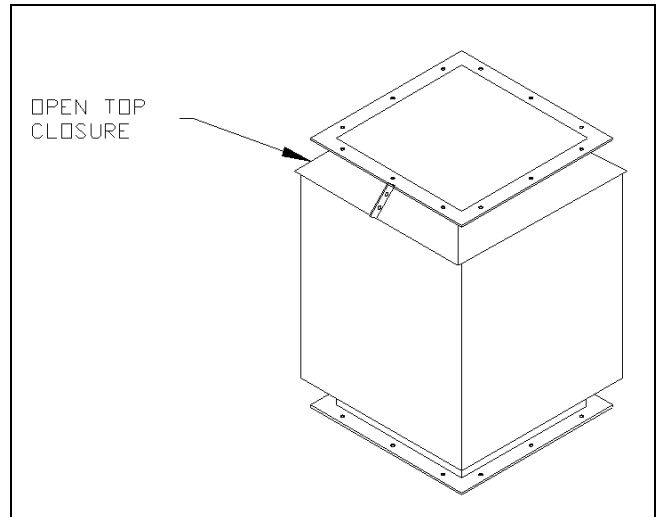

RAIN CAP – PARTS RCS

Rain caps connect to the liner flange per the joint assembly instructions. The space between the liner and shell is then covered using a rain skirt. The rain skirt is installed by positioning the rain skirt around the liner just below the previously installed flange. Next, using the provided fasteners draw up the rain skirt (the rain skirt should be overlapping and in contact with the top of the shell). Last, apply a bead of sealant at the seam formed between rain skirt and the liner to form a weather tight seal.

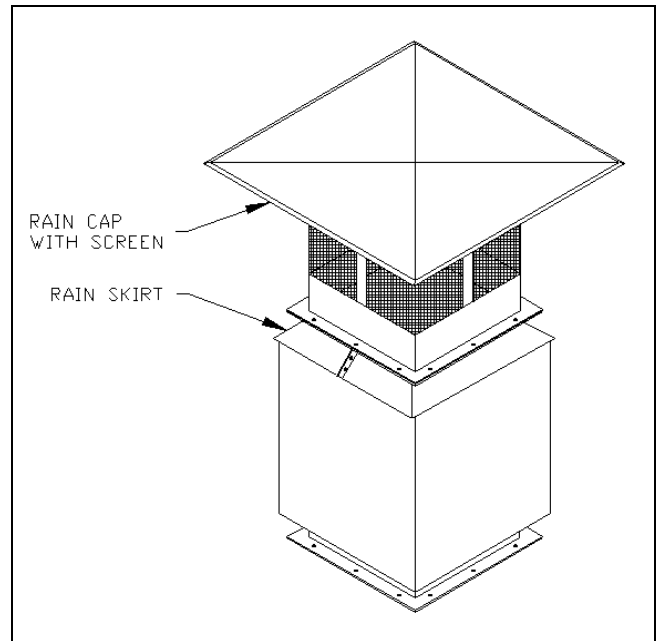

SUPPORTS & GUIDES

NOTES: The structural engineer for the project should select support member channels, beams, rods, wires/cables, etc. and joining methods in accordance with *Good Engineering Practices* to suite each specific application. Rods, wires/cables should only be used for hangers, NOT supports. Van-Packer accepts no responsibility for the design and/or modification of buildings or structures to accept the given load. All support framing, anchoring methods, etc. are by others.

STRUCTURAL SUPPORTS

PLATE SUPPORT ASSEMBLY – PART PLS

Plate support assemblies are used for vertical & horizontal (breaching anchor) structural support applications. The PLS is to be used with structural support members, which are designed by the building structural engineer not Van-Packer. Refer to page 7 for structural support limitations.

STEP 1

Carefully follow the joint assembly instructions on page 6, steps 1 thru 6, with the exception of adding the plate support in-between the flanges. Refer to chart for load limitations. Do not install near combustible material.

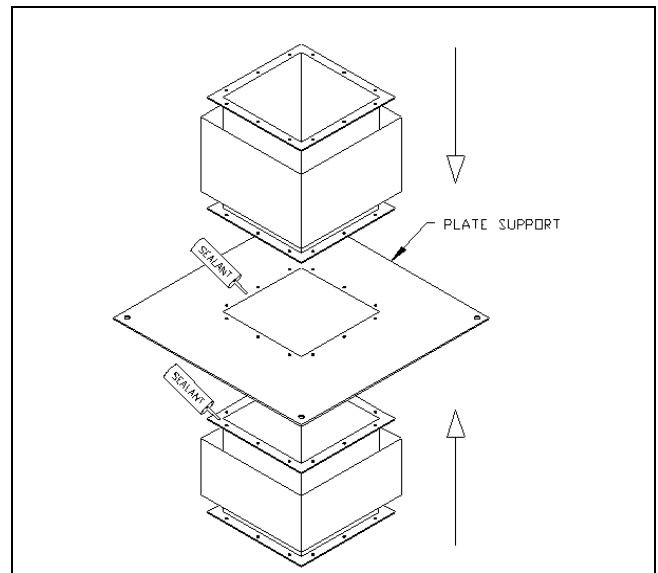

Note:

Support all four sides of the support plate. Design support member and fasteners in accordance with good engineering practices to suit each specific application. Van-Packer assumes no responsibility for the design and/or modification of buildings or structures to accept the given loads.

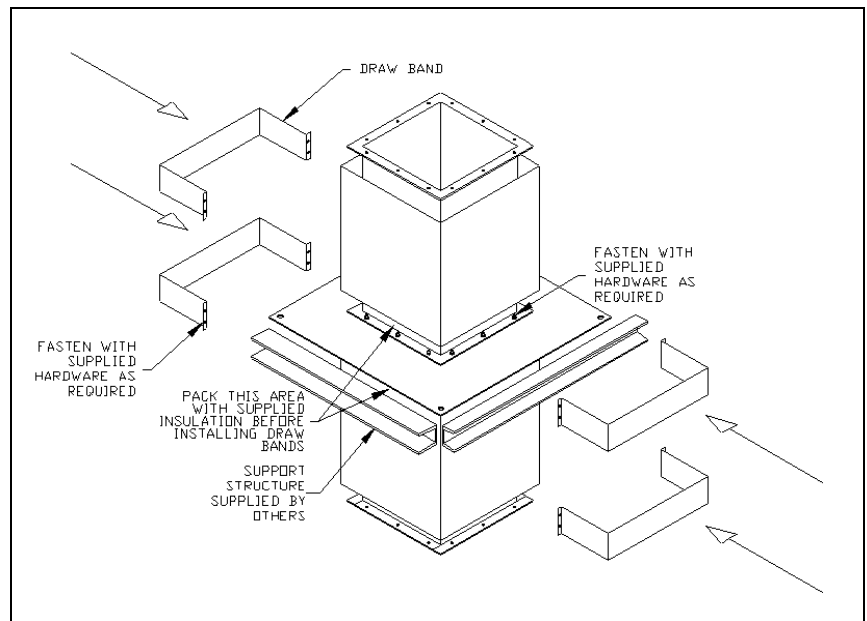

SUPPORTS & GUIDES

STRUCTURAL SUPPORTS - CONTINUED

FLANGE SUPPORT ASSEMBLY – PART FSA

A Flange Support Assembly is a prefabricated section with a plate support installed at the factory for structural support applications. The FSA is to be used with structural support members, which are designed by the building structural engineer not Van-Packer. Refer to page 7 for structural support limitations.

Note:

Support all four sides of the support plate. Design support member and fasteners in accordance with good engineering practice to suit each specific application. Van-Packer assumes no responsibility for the design and/or modification of buildings or structures to accept the given loads. Refer to chart for load limitations. Do not install near combustible material.

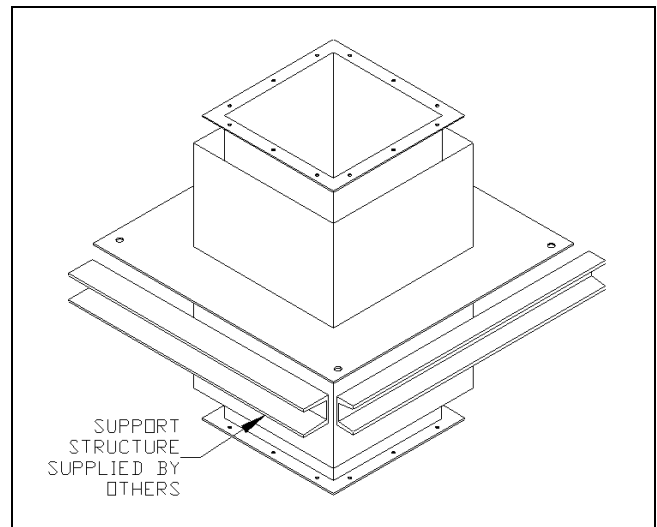

WALL BRACKETS – PART WBR

Wall brackets are used in conjunction with our vertical and horizontal structural and lateral supports. The WBR, in conjunction with anchor bolts or in some instances additional field fabricated support members from the wall brackets to the building or structure, is intended to provide a rigid (static) support location. This rigid support location is intended to withstand the weight of duct components, forces from thermal expansion & exhaust velocities, etc. The WBR is comprised of (2) wall brackets, (left and right) Refer to chart on page 7 for bracket support limitations.

STEP 1

Anchor the wall brackets to the wall or additional field fabricated support members accordingly. Design support member and fasteners in accordance with good engineering practices to suit each specific application. Van-Packer assumes no responsibility for the design and/or modification of buildings or structures to accept the given loads. Refer to chart for load limitations. Do not install near combustible material.

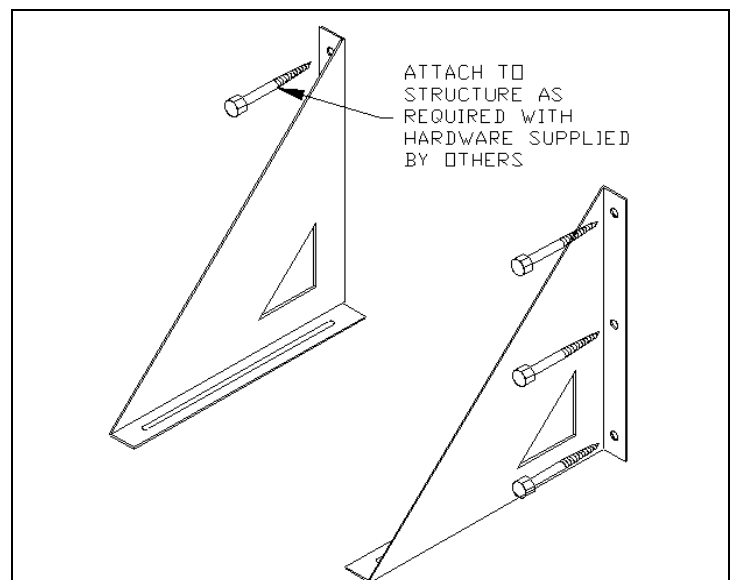

SUPPORTS & GUIDES

HORIZONTAL AND LATERAL SUPPORTS

HORIZONTAL SUPPORTS

We have a few horizontal support options, use supports in conjunction with rods or other field fabricated support members attached to the building or structure. Horizontal supports hold the weight of horizontal assemble and also maintain alignment. Position the support away from draw bands & covers. Please note max. spacing of 12 foot making sure to stay within the weight limitation. Refer to page 7 for support weight limitations.

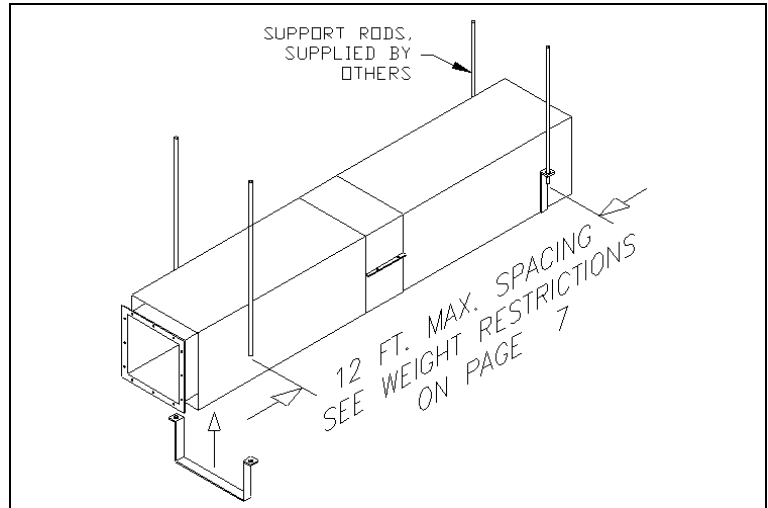

LATERAL BRACES

FULL ANGLE SUPPORT – PART FAS

Full angle supports, in conjunction with field fabricated support members from the FAS attached to the building or structure, are intended to laterally brace the vertical assembled duct lengths from wind loads and to also maintain alignment as the duct expands and contracts. The FAS is comprised of (2) halves and when bolted together is a slight clearance fit to the duct. Position the FAS away from draw bands & covers as to allow for the unrestricted expansion and contraction of the duct system. FAS's cannot be installed over draw bands.

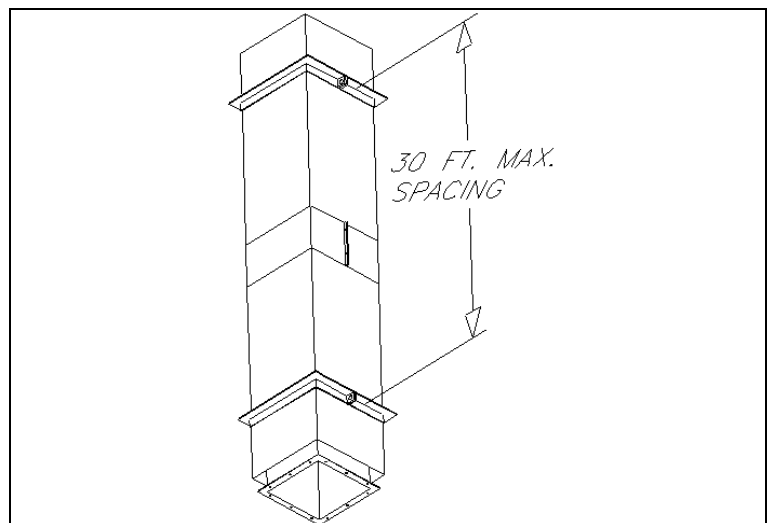

GUY ATTACHMENT PLATE – PART GAP

Guy attachment plate, in conjunction with wires, tensioners, anchors, and other miscellaneous hardware from the GAP attached to the building structure, are intended to laterally brace the vertical assembled duct lengths from wind loads and to also maintain alignment as the duct expands and contracts.

STEP 1

Carefully follow the joint assembly instructions on page 6, steps 1 thru 6, with the exception of adding the Guy attachment plate in-between the flanges.

Note:

Install the necessary wires, tensioners, anchors, miscellaneous hardware, etc. (by others) A minimum of (4) wires/cables equally spaced is recommended.

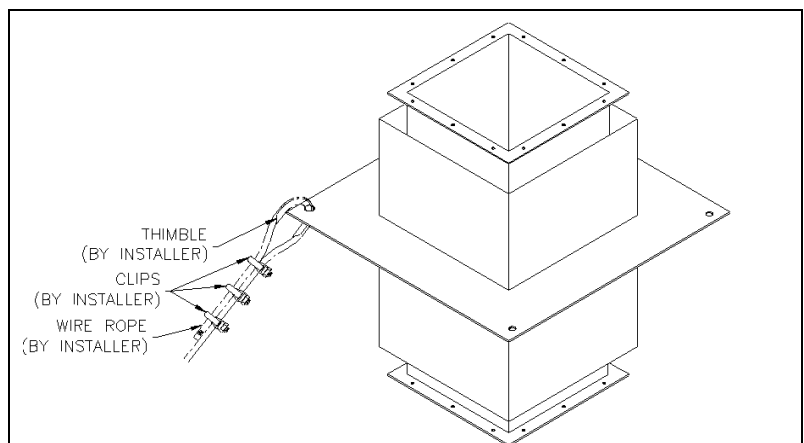

PENETRATIONS & FIRESTOPS

FLOOR PENETRATION ASSEMBLY

FLOOR PENETRATION ASSEMBLY - PART FPA

Refer to "TESTING, CLASSIFICATION, & APPLICATIONS" on page 3 for rating of floor penetration based on duct liner material. This penetration assembly must be used when the duct passes through a fire resistant floor (refer to codes / authorities for specific requirements on fire resistant floors). The duct section passing through the floor must be isolated from the effects of thermal expansion and proper support using one of our structural supports, refer to page 7, 10, and 11 for structural support info. The FPA includes (1) top plate assembly, and one bottom plate assembly, insulation sheet(s) and insulation strips.

STEP 1

Cut the rough floor opening. The rough opening (square or rectangular opening allowed) can vary between duct O.D. +2" and duct O.D. +8" Assemble the duct through the rough opening such that there is a 1" minimum and 4" maximum clearance between any single edge of the opening and the O.D. of the duct. Floor opening shall not exceed 40" x 61".

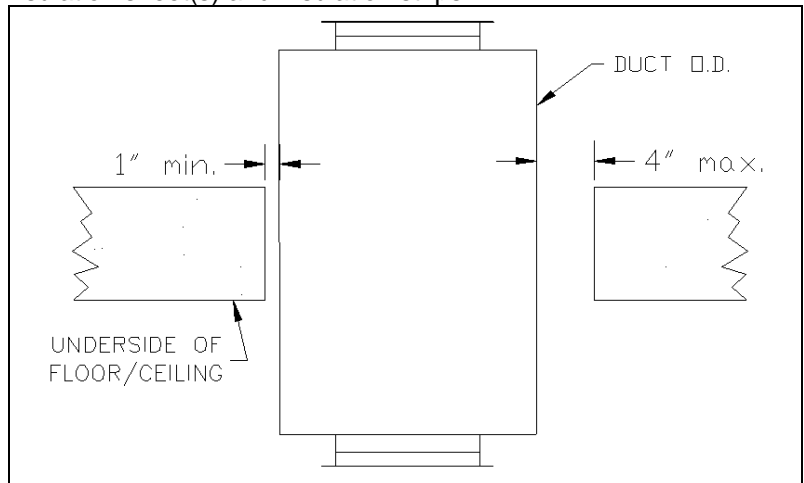

STEP 2

Position the bottom plates around the duct and against the underside of the floor. With fasteners (by others) draw up the plate. Anchor the plate to the floor with concrete screws 1/4" x 1-3/4" min. and then to the duct with No. 6 x 3/4" long sheet metal screws, (by others) at all factory hole locations. Use fire caulk (3M fire barrier or equivalent, by others) to fill any gaps between the plate and the duct or the plate and the floor.

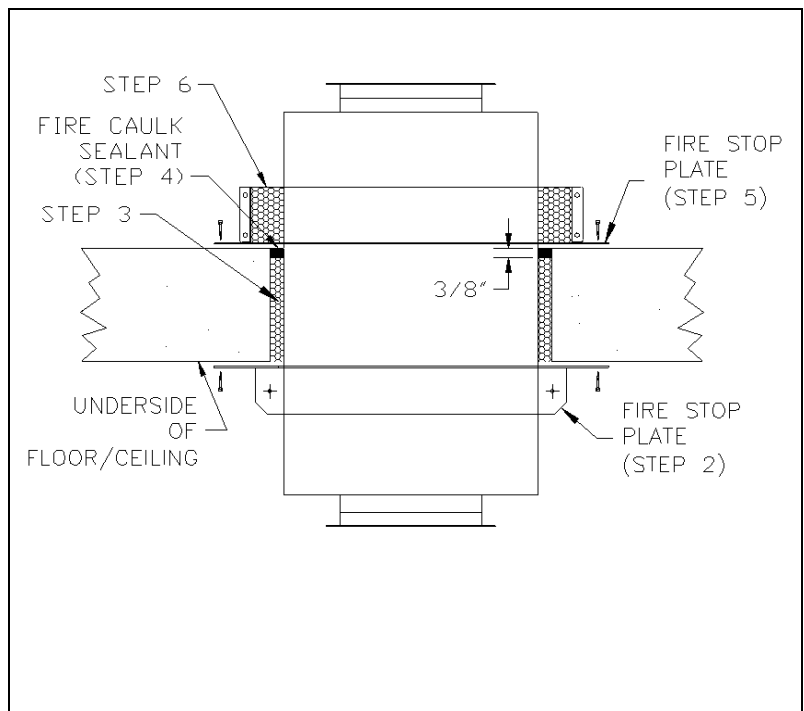

STEP 3

With the provided insulation pack the cavity around the duct and the floor, being careful to stagger any seams or joints. Continue pressing insulation into the cavity until the insulated area is very firm & densely packed to approximately 40% compression leaving a 3/8" recess from top of the floor to the packing material.

STEP 4

Fill the 3/8" void with one of the sealants listed below (by others). Screed the area flush with the top of the floor.

STEP 5

After sealant has skimmed over, install the top plates similar to STEP 2.

STEP 6

Next, install the provided insulation similar to STEP 3, without the 3/8" recess.

Approved Sealants: 3M: 1000-NS, 1000-SL, 2000+ or CP 25 WB+. Tremco: TREMstop Fyre-Sil GG, Fyre-Sil SL. STI: SpecSeal Series SSS. Hilti: FS-ONE

WALL PENETRATION ASSEMBLY - PART WPA

Refer to "TESTING, CLASSIFICATION, & APPLICATIONS" on page 3 for rating of wall penetration based on duct liner material. This type of penetration assembly must be used when the duct passes through an interior fire resistant wall (refer to codes / authorities for specific requirements on fire resistant walls). The duct section passing through the wall must be isolated from the effects of thermal expansion and proper support using one of our structural supports, refer to page 7, 10, and 11 for structural support info. If the duct is passing through a gypsum board wall of appropriate construction, the rough opening between the gypsum boards must be completely closed off and reinforced with metal studs. A CMU (hollow block) wall may also be penetrated. The rough opening should be done in a fashion such that the precast edges of the blocks form a continuous solid edge. Please note: The WPA includes (2) Wall penetration plate assemblies, insulation sheet(s), and insulation strips.

STEP 1

Cut the rough wall opening. The rough opening (square or rectangular opening allowed) can vary between duct O.D. +2" and duct O.D. +8". Assemble the duct through the rough opening such that there is a 1" minimum and 4" maximum clearance between any single edge of the opening and the O.D. of the duct. Wall opening shall not exceed 40" x 61".

STEP 2

With the provided insulation pack the cavity around the duct and the wall, being careful to stagger any seams or joints. Continue pressing insulation into the cavity until the insulated area is very firm & densely packed approximately 40% compression leaving a 5/8" recess from wall to the packing material on both sides of the wall.

STEP 3

Fill the 5/8" void with one of the sealants listed below (by others). Screed the area flush with the edge of the wall.

STEP 4

Position the halves of the plate around the duct and against both sides of the wall. With fasteners (by others) draw up the plate. Anchor the plate to the wall with concrete screws 1/4" x 1-3/4" or self-drilling screws 1/4" x 2" min. and then to the duct with No. 6 x 3/4" long sheet metal screws (by others) at all factory hole locations. Use fire caulk (3M fire barrier or equivalent, by others) to fill any gaps between the plate and the duct or the plate and the floor.

STEP 5

Next, install the provided insulation similar to STEP 3, without the 5/8" recess.

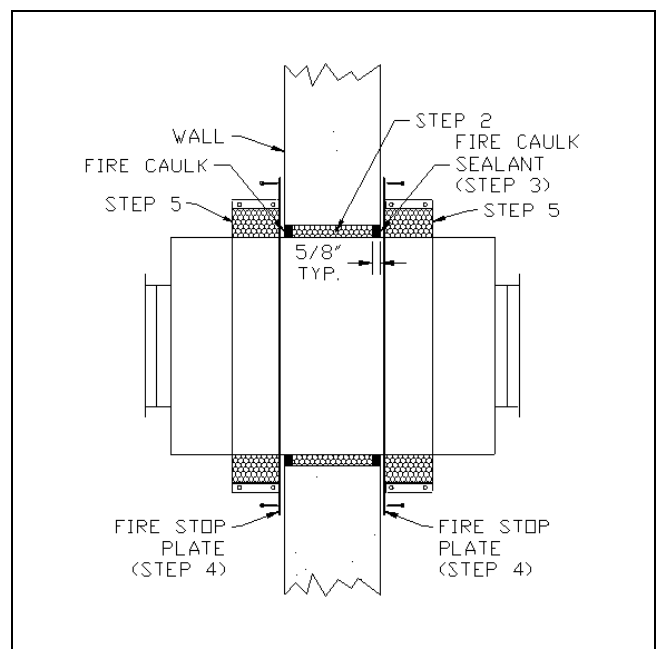
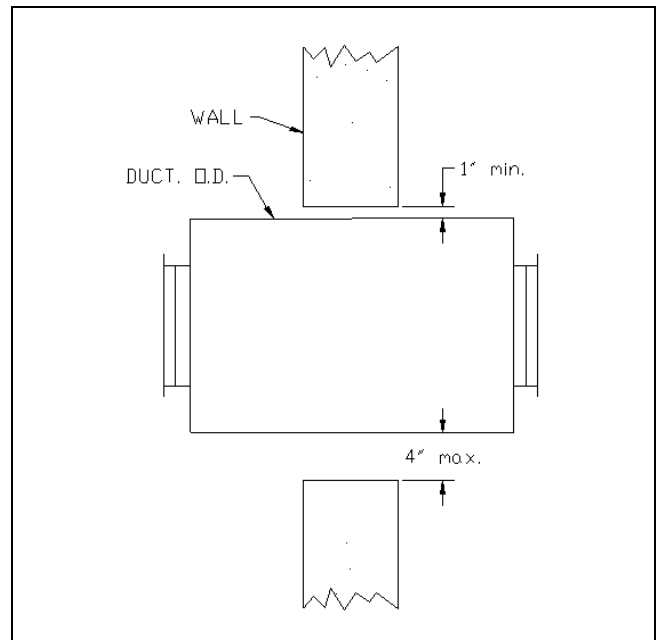

Approved Sealants: 3M: 1000-NS, 2000+ or CP 25 WB+. Tremco: TREMstop Fyre-Sil GG. STI: SpecSeal Series SSS. Hilti: FS-ONE

PENETRATIONS & FIRESTOPS

FLOORS/CEILINGS & WALLS - FIRE RATING NOT REQUIRED

FINISHING PLATE - PART FPL

The finishing plate can be used when the duct passes through a floor/ceiling or wall where a fire rating is not required. The minimum rough opening (square or round opening allowed) must be enough to allow the duct to pass through, approximately duct O.D. +2". The maximum rough opening is duct O.D. +8" (Max. opening size when duct is centered through the opening). The FPL includes (1) plate assembly. Please note two plate assemblies shown below in the picture.

Cut the rough opening accordingly and assemble the duct through. Position the plate halves (allow slight clearance to the duct O.D. to accommodate any expansion as needed), Anchor the plates with appropriate fasteners (by others) at hole locations.

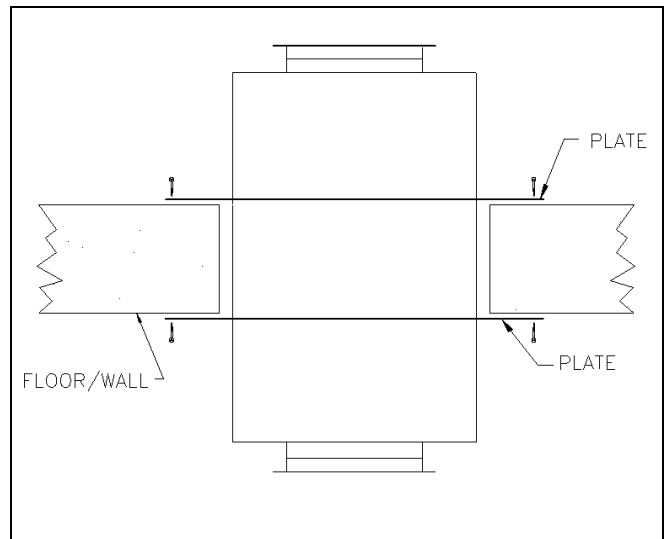

ROOF PENETRATION

FLASHING & COUNTER FLASHING - PARTS FLS & CFL

The flashing and counter flashing can be used when the duct passes through a roof or curb where a roof penetration thimble is not required. Pitched flashings are available please refer to the model GRZ brochure accordingly. The minimum rough opening (square or rectangular opening allowed) must be enough to allow the duct to pass through, approximately duct O.D. +2". The maximum recommended rough opening is duct O.D. +8" (reflects flat roof only and duct centered through opening).

STEP 1

Cut the rough roof opening. Center the flashing around the opening and with appropriate fasteners attach it to the roof. Roofing materials to complete a weather tight seal should be installed over the square base of the flashing.

STEP 2

Assemble the duct through the flashing accordingly. Next, install the counter flashing by positioning it around the duct and against the screen at the top of the flashing. Then, with the provided fasteners draw up the counter flashing. Last, apply a bead of sealant at the seam of the counter flashing and duct. *Note: Roofing materials must not fill the entire space between the roof and the bottom of the counter flashing.*

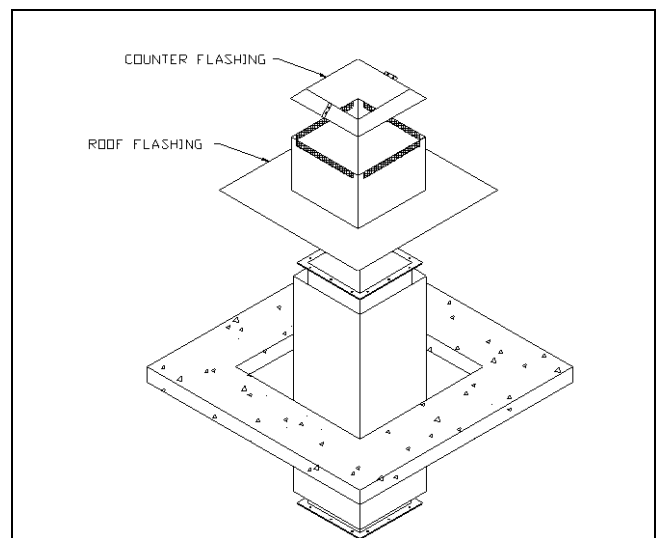

SYSTEM INSTALLATION EXAMPLES

Below shows an installation example. This example is intended to reflect general requirements for support locations, etc. with respect to, fittings, etc. to also show standard supports locations for an installation in accordance with it's design listing. This example may not reflect all necessary cleanouts, drains, etc. which may be required to meet applicable codes and to help ensure a well functioning grease duct system (refer to applicable codes as required).

