

VAN-PACKER® CO., INC.

Model DW Series

**Positive Pressure Guidelines for
Engine Exhaust Systems**

UL Listed under Standard 103 for Flue Gas
Temperatures up to 1400°F (759°C)
Venting System for Factory-Built Chimneys
For Building Heating Appliances



Refer to the General Installation Guidelines for Clearances, Height Limitations, and other General Instructions. Model DWplus Parts are provided with the necessary insulation.

SYSTEM TEMPERATURES Model DW Exhaust operation at 1000°F (538°C) with intermittent temperatures of 1400°F (760°C) or less would be designated as a “Building Heating Appliance Chimney.” Exhaust operating at 1400°F (760°C) with intermittent temperatures of 1800°F (983°C) would be designated as a “1400° Fahrenheit Chimney.” For UL Listing and any additional information regarding applications, enclosures, clearances, etc., refer to the “GENERAL INSTALLATION GUIDELINES.”

EXHAUST SYSTEMS NOT RECOMMENDED Connecting multiple engine exhausts into a common exhaust system is sometimes economically tempting, but is generally not recommended since the pressure of exhausting gases will carry these gases to any engines that are not in operation. These gases that are forced into the exhaust piping of the engine will cool, and condensation could form. This condensate could be harmful to the muffler and engine. You should check with your engine manufacturer before consideration of common exhausts for multiple engines.

HIGH TEMPERATURE JOINT SEALANT (101091F) All engine and turbine exhausts are considered “High Temperature Installations” and require the use of Van-Packer “High Temperature Joint Sealant.” The joint sealant must be placed between the liner flanges and in the groove of the vee band (refer to GENERAL INSTALLATION GUIDELINES).

THERMAL EXPANSION Good installation practice requires that any length of exhaust system between two fixed points subject to more than 1/4” expansion must have compensation for expansion. Adjustable Expansion Sections may be used if the exhaust is on an outside installation where some leakage will not be a problem. The Bellows Expansion Joint is used in high-pressure and interior applications. Axial compression of the Van-Packer bellows is 3” for 6”ID through 18”ID and 3-1/2” for 20”ID through 48”ID. Good installation practice requires that any length of exhaust over two-three feet between fixed points be provided with a bellows joint functioning as an expansion joint together with adequate guidance and support to prevent binding or bending. Bellow Expansion Joints require a fixed point of attachment (plate support) to building structure at each end of each straight run that includes a bellows joint.

LINED / UNLINED BELLOWS Lined Bellow Expansion Joints have a .035” thick stainless steel liner to protect the bellows from heat and flow effects. This part has limited lateral movement (1/8” max.); lateral offsets and parallel misalignment should be eliminated. The liner’s purpose is to reduce heat contact, smooth the flue gas flow and to reduce dirt and other foreign material from building up in the convolutions. The lined bellows is a directional part and the free end is to point downstream (see page 4).

ELBOWS, TEES, AND OFFSETS Angular offsets or horizontal offsets in a vertical stack should be avoided. Offsets require additional expansion joints and rigid fixed points above and below the fittings. Special care should be taken when designing the bracing for elbows and tees because they can only take limited forces due to thermal expansion. Plate Support Assemblies should be used at elbows and tee joints for support. The Plate Support Assemblies are to be braced back to the building with miscellaneous structural steel (provided by others).

PRESSURE RELIEF VALVES The Pressure Relief Valve should be installed on the inlet side of the catalytic converter, waste heat recovery unit or exhaust silencer to relieve the potentially damaging expanding gases should a backfire occur. The valve should be installed outside of the building to facilitate venting of gases to the atmosphere and at an elevation, position, and orientation such that relieved gases cannot be harmful to personnel. Caution: It is imperative that these valves be installed in areas restricted to personnel during operation and in a fire rated area (see page 4).

**Lined / Unlined Bellows Expansion Joint
Part LBJ / BEJ**

The bellows is used as an expansion joint designed to compensate for thermal expansion for high-pressure applications. Maximum compressive travel is 3" for sizes 6"ID - 18"ID and 3-1/2" for sizes 20"ID - 48"ID.

**Bellows Expansion Cover (Optional)
Part BEC**

The *optional* Bellows Expansion Cover is used to shield Lined and Unlined Bellow Joints. A sheet of insulation is provided for DWplus Series.

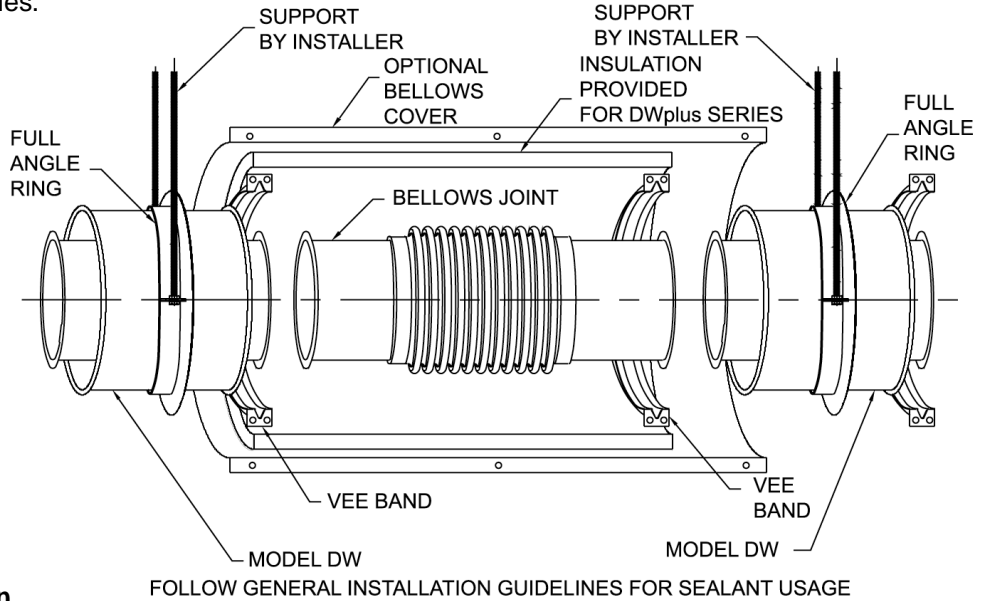

**Variable Length Section
Part VLS**

Use the VLS used for custom length sections. Installed lengths range from 4-1/2" to 19-1/2". It includes a Locking Collar, Vee band, Slip Liner and Cover Band. A sheet of insulation is provided for DWplus Series.

1. Place the locking collar over the slip liner with the flange of the locking collar toward the un-flanged end of the slip liner. Then attach the slip liner to the end of the section that is already in place. Slip the un-flanged end into the next section and adjust to the required length.
2. Place sealant between the slip liner and the section liner, between the locking collar and slip liner, and in the vee band.
3. Slide the flange of the locking collar up to the next liner flange. Tighten the bolts on the locking collar and install a vee band.
4. Install the next section using a vee band in accordance with the joint installation instructions.
5. For DWplus only: cut the sheet of insulation to the required width and install over the slip liner and vee bands.
6. Install cover band over insulation. The cover band may require field-trimming if used between two fittings (elbows, tee, etc.).
7. Allow sealant to cure before operating the appliance (reference page 5).
8. This is a non-load bearing section.

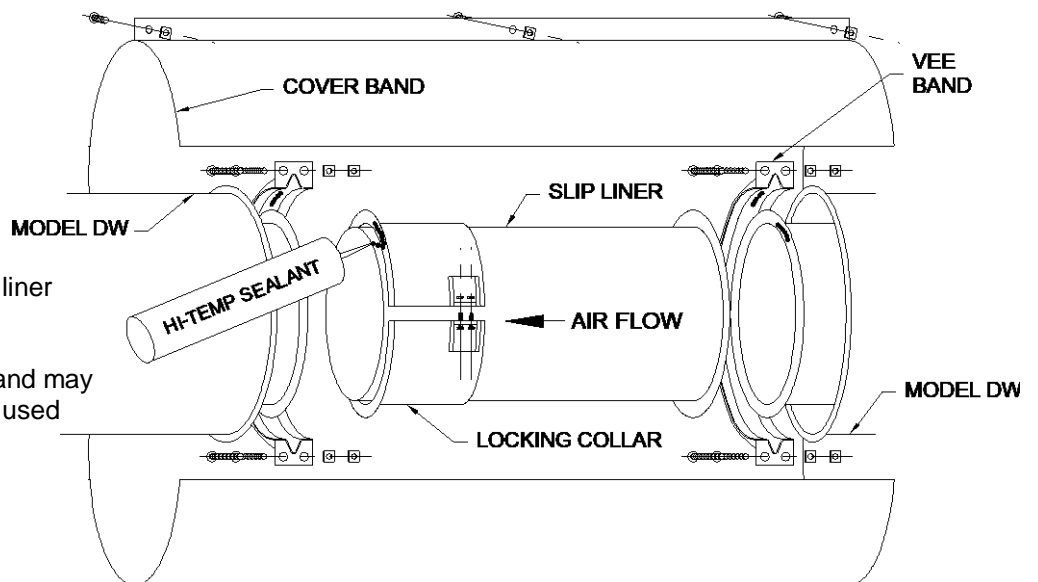

Adjustable Expansion Section

Part ADJ

The Adjustable Expansion Section **can only be used** on exterior portions of engine exhaust systems. The ADJ is used for thermal expansion between two fixed points. A minimum penetration of one half the pipe diameter is required. For interior and high-pressure applications (or as requested), use the Bellows Joint. Refer to the GENERAL INSTALLATION GUIDELINES for proper assembly procedure. Maximum installation length is 19-1/2".

Pressure Relief Valve

Part ERVB

Use the Pressure Relief Valve to relieve exhaust pressure. The ERV must be used in accordance with NFPA 37. **CAUTION** Extreme care *must be used* when determining the location of this valve. If this valve is activated, hot gas, flames and toxicants will be released into the area.

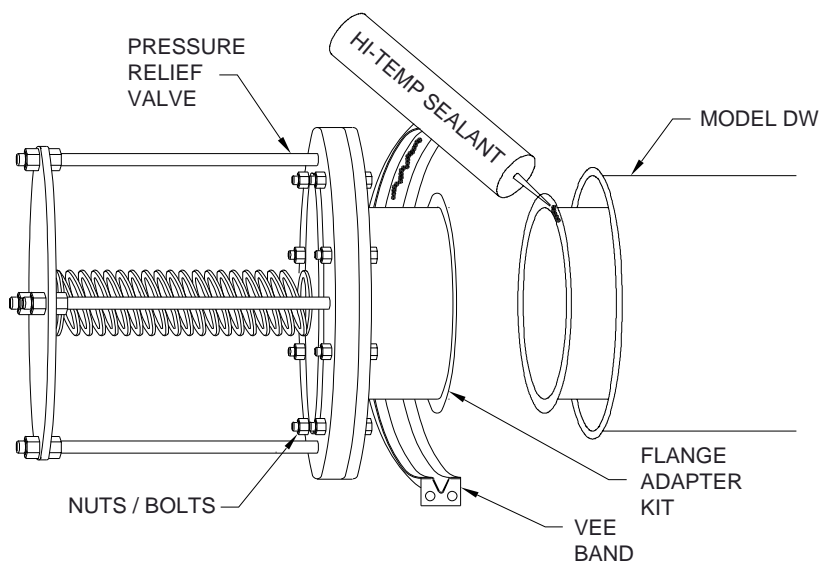

PLATE SUPPORT ASSEMBLY MAY BE USED IN LIEU
OF A VEE BAND

Pressure Relief Valves are for utilization in reciprocating engine exhaust systems to minimize damage caused by engine backfire. They are commonly used to protect exhaust systems where exhaust silencers, catalytic converters, and /or waste heat recovery units are employed. Other applications include installation in reciprocating engine air intake systems to protect against inlet-air-lifter damage due to engine backfire. Pressure Relief Valves are available from 4"Ø through 24"Ø. They are set to open at a pressure of 1-PSIG and rated to relieve the entire exhaust flow of the engine at the design point. They are equipped with 125# American Standard flat face flanges. These valves are designed for operation in exhaust systems where exhaust gas temperatures reach 1300°F.

CAUTION For safety reasons, it is imperative that these valves be installed in areas restricted to personnel during operation.

Flange Adapter Kit

Part FAKB

Use the Flange Adapter when the appliance has a 150# drilling (bolt hole pattern). Place a bead of sealant around flanged outlet about 1/8 inch from inside diameter. Next place flue pipe on top of outlet, align, and fasten down with bolts and nuts by installer. Refer to the "GENERAL INSTALLATION GUIDELINES" for proper installation.

Plate Support Assembly

Part PLS

The Plate Support Assembly is used as the main load bearing member and movement prevention assembly. The split plate and split clamp flange are assembled in two half sections with the seams aligned 90° apart, above and below mating inner pipe joints. The matching holes allow the use of 3/8" bolts and nuts to clamp the inner wall flanges forming a "sandwich" type assembly. Refer to the "GENERAL INSTALLATION GUIDELINES" for proper installation.

Engine Exhaust Side Discharge

Part ESD

The Engine Exhaust Side Discharge is used to horizontally terminate engine/turbine exhaust systems. The side discharge is also available with a bird screen upon request. Part number for this is SDS, Side Discharge with Screen.

1. Place a bead of Hi-Temp Sealant in Vee Band groove and on the section flange.
2. Press up against and align Side Discharge with liner section flange. Make sure 45° cut is installed facing outward.
3. Install Vee Band around flanged joint and tighten down. Refer to the GENERAL INSTALLATION GUIDELINES for proper installation.
4. Install Rain Skirt under and against section liner flange. The Rain Skirt protects the space between the liner and the shell from weather and entry of insects and birds.
5. Place a bead of Silicone Sealant around the top portion of the Rain Skirt to protect from weather. Any exterior portions that require Silicone Sealant shall be supplied and applied by the installer.

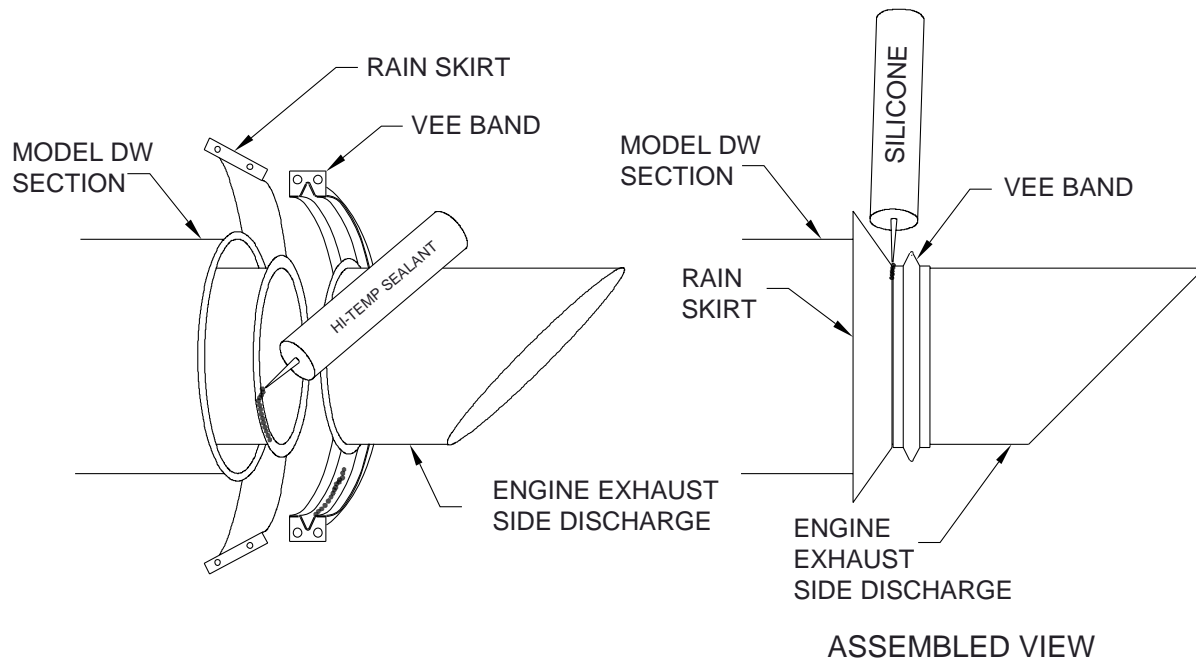

Flip Top Cap

Part FTCB

The Flip Top Cap is for vertical terminations and used to prevent rain from entering generator exhaust pipe. It opens with internal pressure. The FTC is installed the same way as the Engine Exhaust Side Discharge.

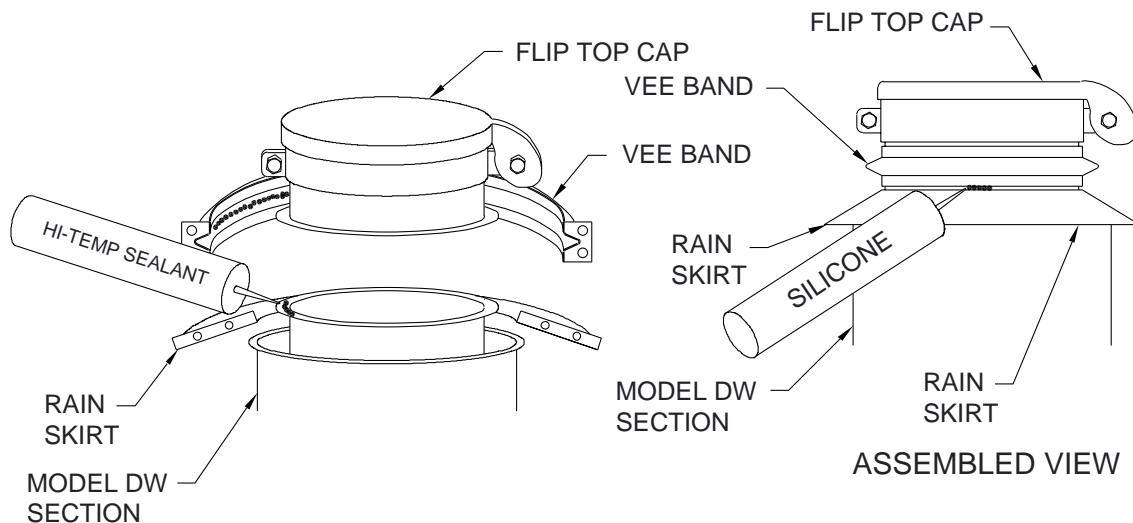

**Van-Packer Company Incorporated
Sales, Service and Manufacturing**

PO Box 307

Buda, Illinois 61314-0302

Phone 1-888-VPSTACK (1-888-877-8225) or Phone 1-309-895-2311

Fax 1-309-895-3891

~~VP Email vptech@theramp.net~~

Tech Email vptech@vpstack.com

Web Site www.vpstack.com

Copyright info: © #141 04/2004